

UNIVERSITY OF CAMBRIDGE INTERNATIONAL EXAMINATIONS  
General Certificate of Education Ordinary Level

**PHYSICS**

**5054/03**

Paper 3 Practical Test

May/June 2005

**CONFIDENTIAL INSTRUCTIONS**

**Great care should be taken that any confidential information given does not reach the candidates either directly or indirectly.**

This document consists of **9** printed pages and **3** blank pages.



## Instructions for preparing apparatus

These instructions detail the apparatus required for each experiment in this paper. A summary of the questions that will be presented to the candidates is included, to allow the Physics teacher to test the apparatus appropriately. No access is permitted to the Question Paper in advance of the examination session.

## Number of sets of apparatus

In addition to a few spare sets, the minimum number of sets of apparatus to be provided should be sufficient to enable candidates to spend 20 minutes with the apparatus for each of Questions 1, 2 and 3, and one hour with the apparatus for Question 4. The order in which candidates answer the questions will be determined by the Supervisor. Candidates may spend one hour circulating around Questions 1, 2 and 3, followed by an hour on Question 4, or vice versa.

Extra graph paper should be available. It is assumed that candidates will supply their own calculator and geometrical instruments, such as a set square,  $0^\circ$  to  $180^\circ$  protractor, pair of compasses and 30 cm rule. Candidates should be advised in advance that they may, if they wish, use quartz wristwatches with stopwatch facilities, providing that such wristwatches afford the required precision.

## Instructions for the supervision of the examination

The Supervisor, who may be a Physics teacher, is responsible for the administration of the examination according to the procedures detailed in the Handbook for Centres. In all instances, a Physics teacher should be present. Preferably, this teacher should have been responsible for the preparation of the apparatus. Two invigilators must be present at all times: it is not acceptable for a teacher who has been responsible for preparing the candidates for this paper to be the sole Supervisor or Invigilator.

Supervisors may make the following announcement at the start of the examination.

'The Examiners do not want you to waste time when you are unable to do any experiment. Any candidate who is unable to get results with an experiment may ask for help. The extent of this help will be reported to the Examiners, who may make a deduction of marks.'

Supervisors should note that a candidate may only be given enough assistance to allow some raw readings or observations to be made. On no account should any assistance be given with the treatment or analysis of these readings and observations.

Supervisors may draw to the attention of the candidates any significant deviation between the apparatus provided and that detailed in the Question Paper, particularly where diagrams are given in the paper.

Candidates should be reminded that all their work should be written on the printed Answer Booklet. Rough paper must not be used.

The Supervisor must complete the Report at the back of these Instructions. Details should be given of any significant deviation between the apparatus used and that specified in these Instructions. A sample set of results can often help Examiners. A copy of this Report must be included in **each** packet of scripts.

**1 Items to be supplied by the Centre (per set of apparatus, unless otherwise specified)**

250 cm<sup>3</sup> glass beaker

Metre rule

100 cm length of thin string

Fine-tipped marker pen or fine felt-tip pen

Access to a balance reading to at least 0.1 g

**Notes**

- (i) A new length of thin string should be provided for each candidate.
- (ii) The marker pen is to be used by the candidates to mark the length of string.
- (iii) The string must be long enough to go around the beaker at least four times.

**Information required by examiners**

Height and diameter of the beaker.

**2 Items to be supplied by the Centre (per set of apparatus, unless otherwise specified)**

250 cm<sup>3</sup> Pyrex beaker

100 cm<sup>3</sup> Pyrex beaker

Supply of boiling water

–10 °C to 110 °C thermometer

Stand, boss and clamp to hold the thermometer

Plastic stirrer

Stopwatch

Paper towels to mop up any spillages

**Notes**

- (i) The supply of boiling water should be close to the apparatus being used by the candidates so that candidates do not have to carry boiling water across the laboratory e.g. an electric kettle could be placed between two workstations. Candidates will have to transfer very hot water to the beaker and Supervisors must ensure that this can be done safely.
- (ii) The Supervisor should clamp the thermometer vertically with the bulb of the thermometer in the larger beaker. The thermometer must not be directly over the base of the stand so that the thermometer may be moved from one beaker to the other without adjusting the clamp and boss. This is shown in Fig. 2.1. The bulb of the thermometer should be just above the base of the larger beaker. The Supervisor should ensure that the clamp does not obscure the scale of the thermometer in the region of 90 °C to 70 °C. Once the thermometer is clamped in the correct position, the Supervisor should indicate with a label that the clamp and boss should not be adjusted during the experiment.

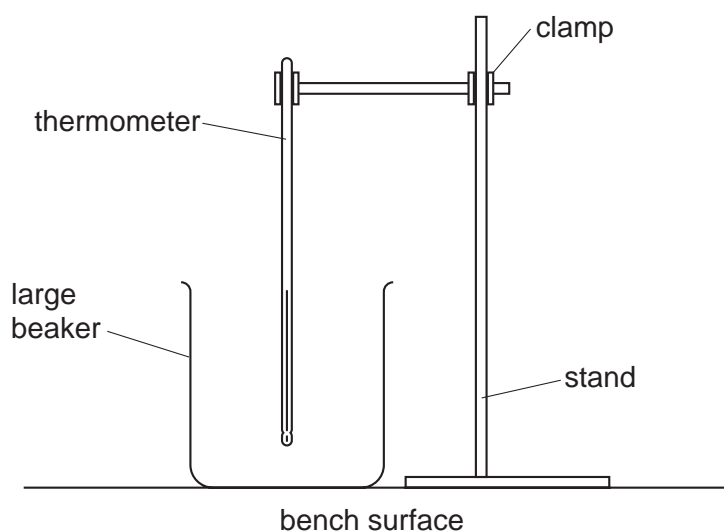

**Fig. 2.1**

- (iii) Before the examination, the Supervisor should mark the two beakers as follows. The Supervisor should pour sufficient cold water into the 250 cm<sup>3</sup> beaker so that the water just covers the bulb of the thermometer. The level of the water should then be marked on the outside of the beaker with a permanent marker pen. The same volume of water should then be poured into the smaller beaker and its level marked. The water should then be discarded.
- (iv) The apparatus should be arranged on the bench with the thermometer held in the clamp and placed in the smaller beaker, with the bulb just above the base.
- (v) At the changeover, the Supervisor should discard the water in the two beakers. The supply of boiling water should be replenished if necessary. The thermometer should be replaced in the smaller beaker.

**Information required by examiners**

None.

### 3 Items to be supplied by the Centre (per set of apparatus, unless otherwise specified)

Variable d.c. power supply to enable three voltages between 1 V and 6 V to be applied to a filament lamp, e.g. three 1.5 V cells in a cell pack

Approximately 6 V, 0.3 A filament lamp in a suitable holder

Switch or plug key (the question paper will refer to a switch)

Ammeter capable of reading up to 0.5 A to a precision of at least 0.01 A, e.g. a 1.0 A full scale deflection analogue meter or a 2.0 A digital meter

Voltmeter capable of reading up to 6 V to a precision of at least 0.1 V, e.g. a 10 V full scale deflection analogue meter or a 20 V digital meter

6 connecting leads

#### Notes

- (i) The lamp-holder should have suitable terminations to enable it to be connected into the remainder of the circuit.
- (ii) The Supervisor should set up the circuit as shown in Fig. 3.1 with the power supply voltage set between 1 V and 2 V. The switch should be open i.e. the circuit is not complete.

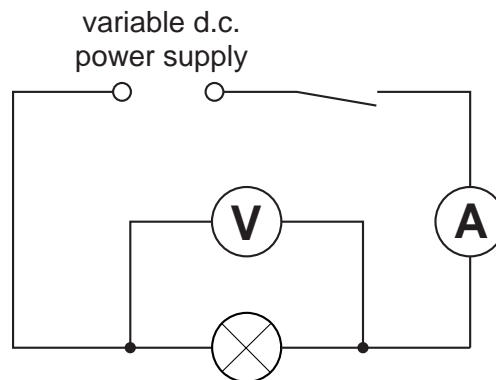

**Fig. 3.1**

- (iii) At the changeover, the Supervisor should ensure that the circuit is set up as shown in Fig. 3.1 with the power supply voltage set between 1 V and 2 V. The Supervisor should check that the lamp is still operational and that any cells used in the circuit have not run flat. The Supervisor should then open the switch.

#### Information required by examiners

Nominal voltage and current rating of lamp.

#### 4 Items to be supplied by the Centre (per set of apparatus, unless otherwise specified)

Pendulum bob

Thin string of approximate length 1 m

Split cork which can be used to provide a well-defined point of suspension for the pendulum

Tall stand, boss and clamp to support the split cork

Optics pin in another cork to provide a fiducial marker

Second boss and clamp to hold the fiducial marker

Metre rule

Set square

Stopwatch

#### Notes

- (i) Using the thin string and the pendulum bob, the Supervisor should construct a simple pendulum. The string of the pendulum should pass through the split cork that is supported by the clamp and stand. The clamp should be held close to the top of the stand with a label on the boss stating "Do not adjust the boss". The length of the string should be adjusted so that the centre of the pendulum bob is approximately 5 cm above the bench surface, as shown in Fig. 4.1.

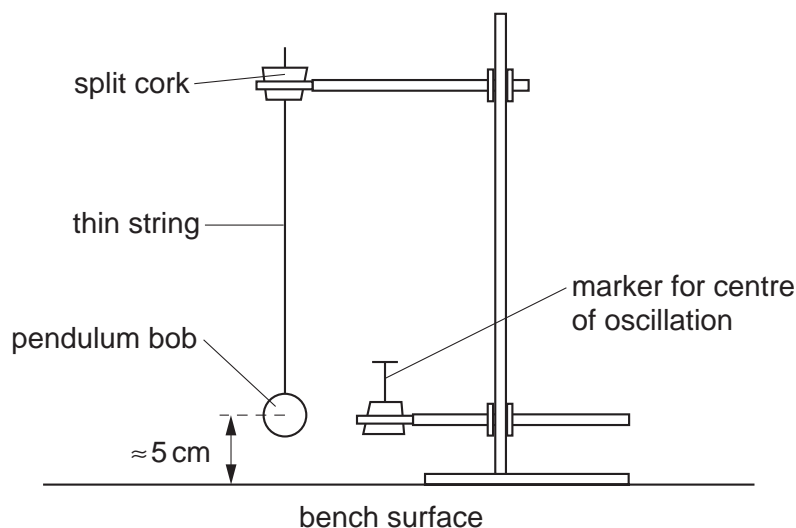

**Fig. 4.1**

- (ii) The second boss and clamp should be used to hold the fiducial marker, as shown in Fig. 4.1.
- (iii) At the changeover, the Supervisor should check that the apparatus is still as shown in Fig. 4.1.

#### Information required by examiners

None.





**BLANK PAGE**

**BLANK PAGE**

---

Permission to reproduce items where third-party owned material protected by copyright is included has been sought and cleared where possible. Every reasonable effort has been made by the publisher (UCLES) to trace copyright holders, but if any items requiring clearance have unwittingly been included, the publisher will be pleased to make amends at the earliest possible opportunity.

University of Cambridge International Examinations is part of the University of Cambridge Local Examinations Syndicate (UCLES), which is itself a department of the University of Cambridge.

**This form must be completed and returned with the Answer Booklets.**

### REPORT ON PRACTICAL PHYSICS

The Supervisor is asked to give the following details, using the space provided on page 12.

- (a) Information required at the end of the test, as indicated in the Instructions.
- (b) Any help given to a candidate.
- (c) Any general difficulties encountered in preparing the apparatus.
- (d) Any difficulties experienced by particular candidates. These should include reference to difficulties due to faulty apparatus or materials and accidental damage to apparatus or materials. Candidates should be identified by name and candidate number.

Other cases of hardship, such as disability or illness, should be reported to CIE in the normal way.

The Supervisor is asked to provide a plan of the work benches, giving details by candidate numbers of the places occupied by the candidates for each session. The plan should be enclosed with the Answer Booklets, together with the Information required by Examiners.

#### Declaration to be signed by the Principal

The preparation of this practical examination has been carried out so as fully to maintain the security of the examination.

Signed .....

Name (in block capitals) .....

Centre Number .....

Centre Name .....



**Information required**

Dimensions of beaker used in question 1:

height = .....

diameter = .....

Nominal ratings of lamp used in question 3:

voltage rating = .....

current rating = .....

**Details of difficulties and any help given to candidates**