



DESIGN AND TECHNOLOGY

6043/01

Paper 1 Technology

For Examination from 2016

SPECIMEN PAPER

2 hours 30 minutes

Additional Materials: Answer Booklet/Paper

Plain paper

Sketching equipment

READ THESE INSTRUCTIONS FIRST

If you have been given an Answer Booklet, follow the instructions on the front cover of the Booklet.

Write your Centre number, candidate number and name on the work you hand in.

Write in dark blue or black pen.

You may use an HB pencil for any diagrams, graphs or rough working.

Do not use staples, paper clips, glue or correction fluid.

DO NOT WRITE IN ANY BARCODES.

Part A

Answer **all** questions.

Part B

Answer **four** questions.

Answer **two** questions from Section 1 and **two** questions from Section 2.

You are advised to spend no longer than 45 minutes on Part A.

Use sketches where appropriate to help answer any question. You may use coloured pencils.

The number of marks is given in brackets [] at the end of each question or part question.

At the end of the examination, fasten all your work securely together.

This document consists of **11** printed pages and **1** blank page.

Part A

Attempt **all** questions.

1 State **two** simple workshop tests that would help to identify a plastic. [2]

2 Fig. 1 shows a metalworking device.

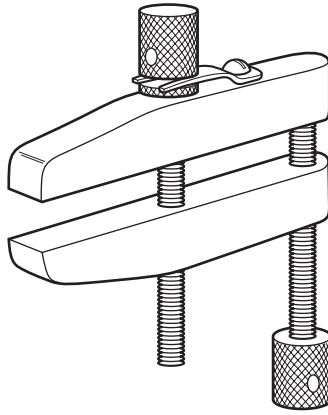

Fig. 1

(a) Name the device.

(b) Explain its use.

[2]

3 What is meant by the term 'K.D. fitting' when applied to furniture? [2]

4 Fig. 2 shows the expanded polystyrene packaging for an electrical component.

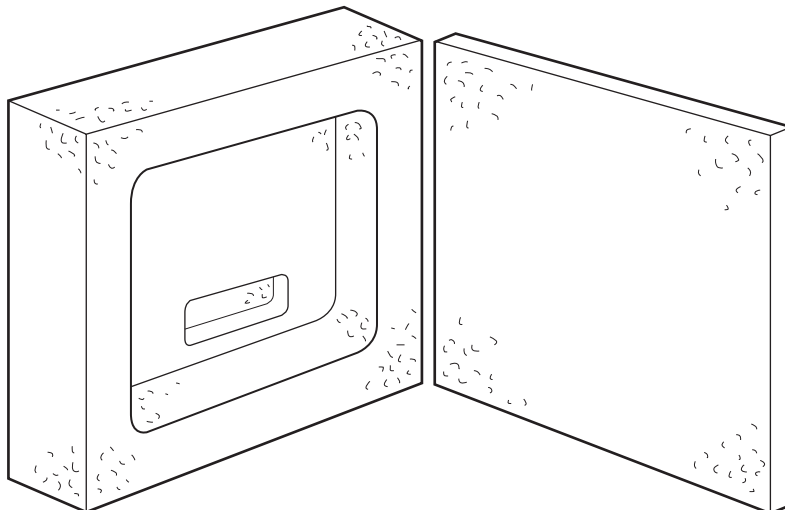

Fig. 2

(a) State **two** reasons why expanded polystyrene has been chosen.

(b) State **one** reason why polystyrene is harmful to the environment.

[3]

5 State how the shape is formed in the following processes.

(a) laminating

(b) blow moulding

(c) casting

[3]

6 Sketch the following fittings.

(a) hexagonal bolt

(b) butt hinge

[4]

7 Fig. 3 shows details of a plywood puzzle ready for cutting.

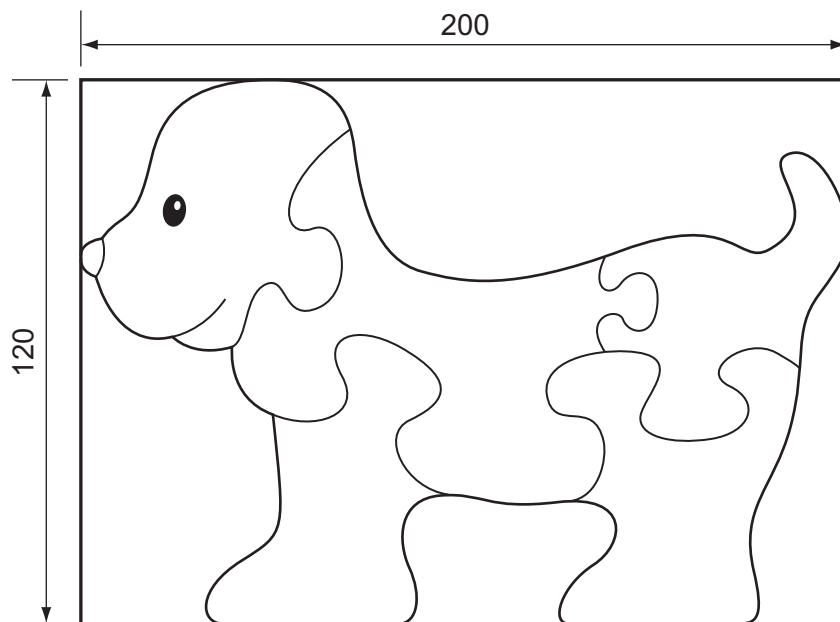

Fig. 3

(a) Name a saw that could be used for cutting out the shape and give a reason for your choice.

(b) What action should be taken to prevent the plywood splintering?

[4]

8 Give **two** reasons why melamine is used for decorative kitchen surfaces.

[2]

9 State **three** adhesives used for joining wood.

[3]

10 Explain briefly the term 'swarf' and state **two** ways in which it can be dangerous.

[3]

Part B

Attempt **four questions**, **two** from Section 1 and **two** from Section 2.

All questions carry equal marks.

Section 1 – Tools and Materials

11 Three common hand tools are shown in Fig. 4.

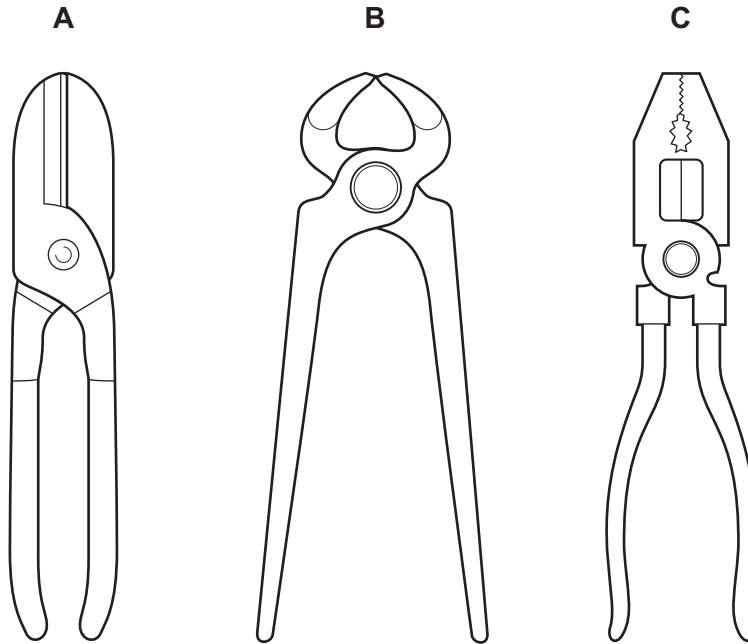

Fig. 4

- (a) Name and state a use for each tool. [6]
- (b) Explain:
- (i) why tool **A** is limited in its use
 - (ii) how tool **B** uses leverage
 - (iii) why tool **C** can be called multi purpose. [6]
- (c) Sketch the following and explain the purpose of each.
- (i) a pair of forge tongs
 - (ii) a tap wrench [6]

12 Abrasives have an important role to play in the craft workshop.

(a) What is the purpose of using abrasives when finishing work? [2]

(b) Describe briefly how waste generated when using abrasives could be harmful when finishing a project made from:

(i) pine

(ii) copper

(iii) acrylic. [4]

(c) Show, by means of sketches, how the following help when finishing a surface or edge with an abrasive.

(i) a file

(ii) a wooden block [6]

(d) Abrasives help to maintain tools.

Explain, with the aid of sketches, how abrasives could restore the following tools.

(i) a blunt chisel blade

(ii) a chipped screwdriver blade [6]

13 The design for a laminated finger ring is shown in Fig. 5.

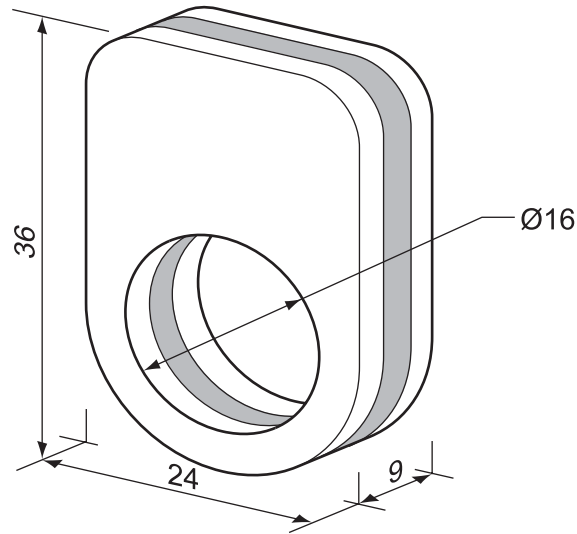

Fig. 5

(a) From each of the material groups given below, suggest a specific material that would be suitable for the two outer laminations. In each case, give one reason for your suggested material.

(i) metal

(ii) plastic

(iii) wood

[6]

(b) Choose **one** of the specific materials you have named in answer to part (a) and suggest a contrasting material for the centre lamination.

Name and sketch the tools and materials that would be used to:

(i) join the three parts together

(ii) hold and drill the finger hole

(iii) cut out the outside shape.

[9]

(c) From the three material groups listed below, state the group that could be considered to be the most sustainable and give a reason why this is the case.

(i) metal

(ii) plastic

(iii) wood

[3]

14 A wide variety of materials are used in the workshop.

(a) Copy and complete the chart below, giving the process/use and reason for use, for each material.

| Material | Process / Use | Reason for use |
|----------------|-------------------------|--|
| Chalk | Filing a piece of metal | To stop the file from clogging with waste material |
| Soft solder | | |
| Acid | | |
| Plastic cement | | |
| Wire wool | | |
| Sand | | |

[15]

(b) Soft solder is now made in 'lead free' form. Explain briefly why this is.

[3]

Section 2 – Processes

15 Fig. 6 shows the outline design for a door stop.

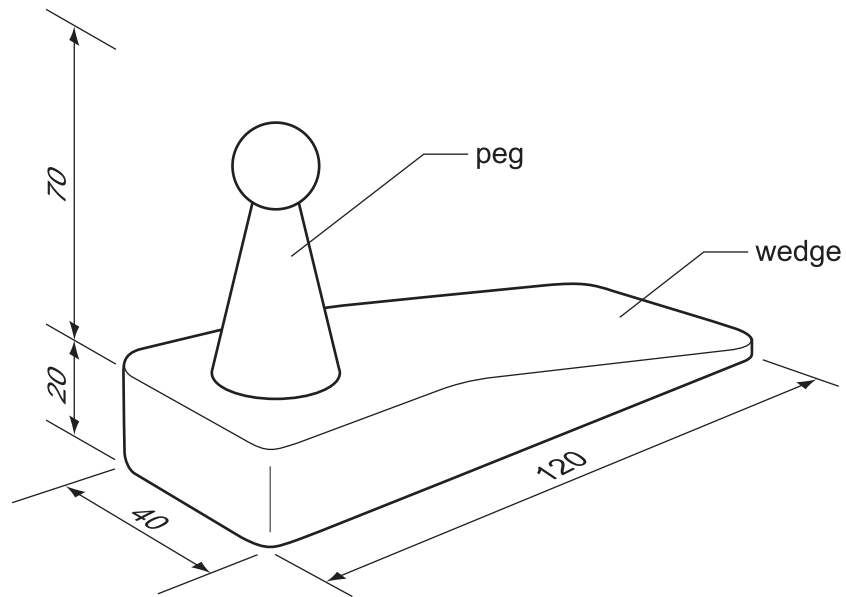

Fig. 6

- (a) Suggest a suitable material and process for making the door stop that would minimise waste. [3]
- (b) Using the material chosen in (a), describe the process of making the door stop. [8]
- (c) The peg is to be decorated.
- (i) Show, by means of a sketch, a design that could be applied to the peg. [2]
- (ii) Describe in detail how the design may be applied to the surface of the peg. [5]

16 A knowledge of how materials may be joined is important when designing products.

Choose **two** of the following processes and, using notes and sketches, describe how they are carried out.

(a) brazing together two curved mild steel flat bars

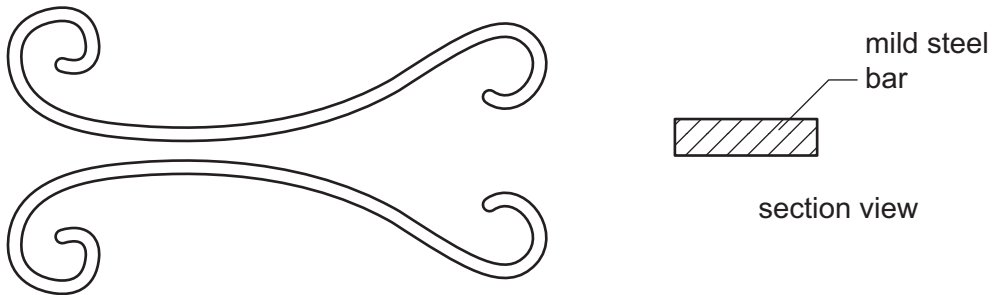

Fig. 7

(b) cutting out a dovetail joint for a mahogany box

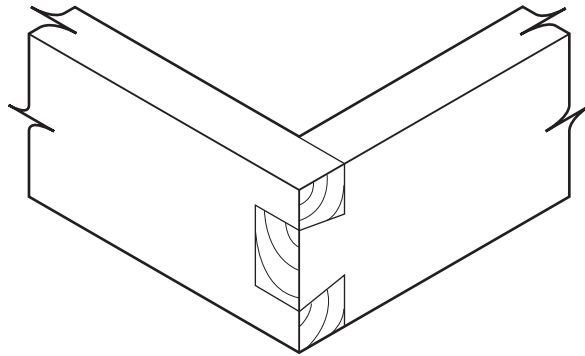

Fig. 8

(c) bending and joining an acrylic base to an acrylic tube

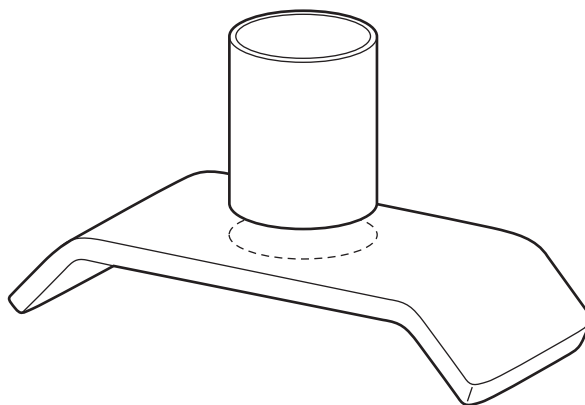

Fig. 9

[18]

17 Fig. 10 shows details of an adjustable rack, designed to fit doors of different widths.

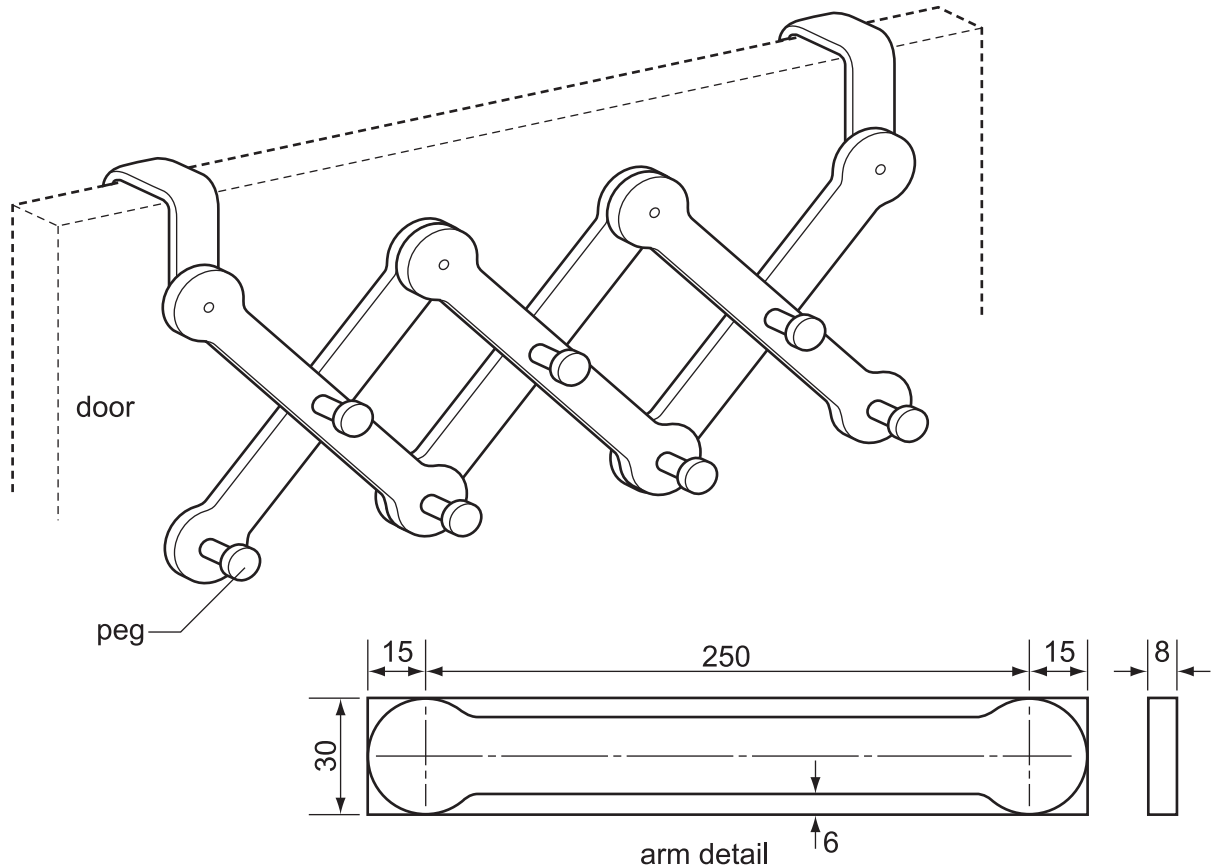

Fig. 10

- (a) Choose a suitable material for the rack and suggest a method of joining the arms that would allow adjustment of the rack. [2]
- (b) (i) For the material chosen in (a), describe the process of marking out one arm. [5]
- (ii) For the material chosen in (a), describe the process of cutting the arms to shape. [5]
- (iii) Cutting to shape is a wasteful method of production. Suggest an alternative, more efficient method of manufacture. [2]
- (c) Using notes and sketches, describe how the pegs could be fitted to the rack. [4]

18 An idea for an outdoor game is given in Fig. 11.

It is based on a game in which the players take it in turns to drop coloured discs into a frame. The holes in the board allow the players to see who can get four in a row.

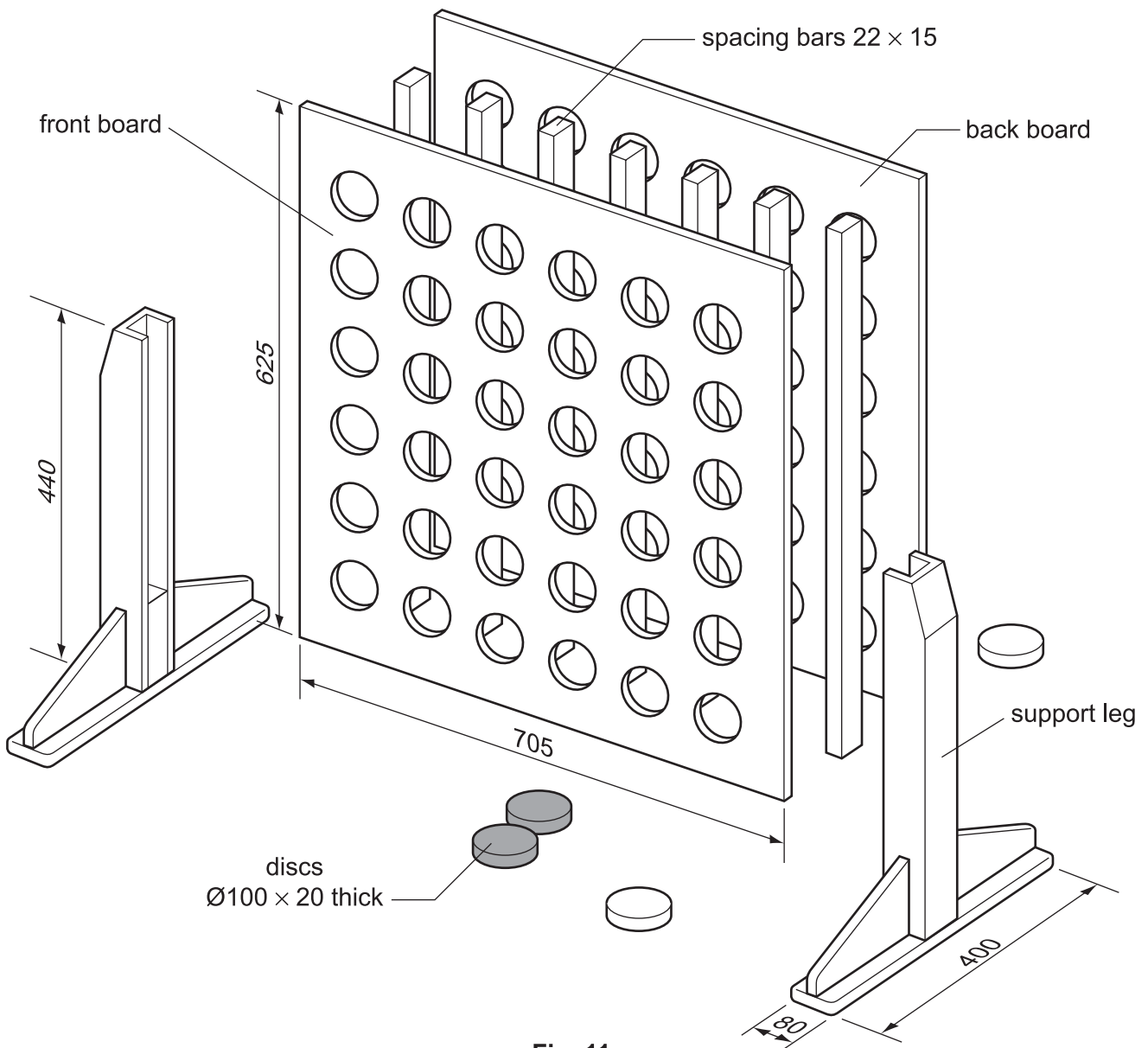

Fig. 11

- (a) For each named part of the game, identify suitable materials to be used, and describe, with the aid of sketches and notes, the following processes.
- (i) supporting, holding and cutting out the $\text{Ø}70$ holes in the front and back boards of the frame [5]
 - (ii) positioning and fixing the spacing bars to the front and back boards of the frame [5]
 - (iii) making the support legs for the frame [5]
- (b) Design, with the aid of a sketch, a method of supporting the discs at the bottom of the frame and releasing them once the game is ended. [3]

Permission to reproduce items where third-party owned material protected by copyright is included has been sought and cleared where possible. Every reasonable effort has been made by the publisher (UCLES) to trace copyright holders, but if any items requiring clearance have unwittingly been included, the publisher will be pleased to make amends at the earliest possible opportunity.

Cambridge International Examinations is part of the Cambridge Assessment Group. Cambridge Assessment is the brand name of University of Cambridge Local Examinations Syndicate (UCLES), which is itself a department of the University of Cambridge.