



Cambridge Assessment
International Education

Coursework Handbook

Sample projects

Cambridge O Level

Design & Technology 6043

For examination from 2020



In order to help us develop the highest quality resources, we are undertaking a continuous programme of review, not only to measure the success of our resources but also to highlight areas for improvement and to identify new development needs.

We invite you to complete our survey by visiting the website below. Your comments on the quality and relevance of our resources are very important to us.

www.surveymonkey.co.uk/r/GL6Z NJB

Would you like to become a Cambridge International consultant and help us develop support materials?

Please follow the link below to register your interest.

www.cambridgeinternational.org/cambridge-for/teachers/teacherconsultants/

Copyright © UCLES 2018

Cambridge Assessment International Education is part of the Cambridge Assessment Group. Cambridge Assessment is the brand name of the University of Cambridge Local Examinations Syndicate (UCLES), which itself is a department of the University of Cambridge.

UCLES retains the copyright on all its publications. Registered Centres are permitted to copy material from this booklet for their own internal use. However, we cannot give permission to Centres to photocopy any material that is acknowledged to a third party, even for internal use within a Centre.

Contents

Introduction	4
Section 1: Project A – Jewellery box	5
1.1 Moderator's assessment of Project A	
Section 2: Project B – Environmentally-friendly egg carton	40
2.1 Moderator's assessment of Project B	
Section 3: Project C – Auto-tempered fan	67
3.1 Moderator's assessment of Project C	

Introduction

This is the section of the handbook which contains the sample projects for you to mark.

Please make sure you refer the handbook for the marking criteria.

The three projects are:

- Project A – Jewellery box
- Project B – Environmentally friendly egg carton
- Project C – Auto-tempered fan

Section1: Project A – Jewellery box

Context & Design Need:

Teenagers and young adults collect jewellery over a period of time. They buy some while others are gifts from friends and family. Often the jewellery is scattered on dressers, kept in small boxes or drawers, making them difficult to locate and increasing the risk of these valuable items being lost or misplaced.

As a teenage girl, from my own experiences and discussing the problem with friends, I found out that this is a common issue. Jewellery is often not properly looked after and is sometimes misplaced only to be found later in some strange places. Jewellery is often not secure or protected and can get damaged by knocking against other items. This damages the finish and is costly to repair.

What's needed is a unique storage device that can keep all these items in one place, is easily accessible and protects the jewellery too. The device could be modular so new layers or tiers can be added to accept more jewellery. The main selling point should be the unusual form, aesthetics and special functions that are not commonly available in other such devices.

Design Brief:

To design and make a jewellery box that would store a variety of different types of jewellery while ensuring that they don't get damaged. This product is aimed at young adults as they tend to own more jewellery, in particular females.

Brief Analysis - End User Requirements (Feedback from Questionnaire):

- ❖ The compartments should be wide enough to store the jewellery, the whole unit should enable the user to store lots of them.
- ❖ The product should be relatively light wherein the user will be able to transport it/ move it around.
- ❖ The product should be made of materials that are strong, rigid, durable. So that it lasts for a long period of time.
- ❖ The user should be able to access their their jewellery fairly easily.
- ❖ The product should be attractive and aesthetically pleasing.
- ❖ The product should enable the user to store different types of jewellery.
- ❖ The size of the product shouldn't be big, it should be of a size that would be easily placed on a table without taking up too much space.

Key Questions & Answers:

1. Where does the problem exist (Design need or opportunity)?

The design is needed to store the user's' jewellery so that most of their jewellery will be stored in one place and not in several containers at different locations.

2. Who does the problem affect? Age, sex, particular groups of people etc.

This problem affects young adults, mostly female but it also affects male. People who own lots of jewellery face this problem. Jewellery is expensive and people want to look after it, display it properly and show it off.

3. What are the consequences of the problem? (Negative impact on users)

If the jewellery aren't stored in one place, they could get lost and get damaged. The user will need to spend lots of time trying to figure out/remember where they placed their jewellery.

4. What solutions are already available (What are their pros and cons)?

There are already jewellery boxes available to the user, which means that they can use them. But most of the jewellery boxes have the same design, some are really small and some of them don't give the choice to the user as to what type of jewellery can be stored. Users tend to have several boxes for jewellery and other personal items. This can make it difficult to keep track of jewellery.

5. Which environments would be suitable for my product and why?

The product has to be placed indoors on flat surfaces, where the user usually places their jewellery box. Any room environment / area is suitable as long as it is secure and away from the rain. This product is likely to be used used at home, in a bedroom for example. However, it should be portable enough to move to other rooms, locations, transport in a car etc.

6. What are the limitations I need to consider? (Cost, weight, size, complexity etc)

The cost of the of the product shouldn't be too expensive for young adults to afford. It has to have a unique shape and work a bit differently than most boxes available. The product should be relatively light so that the user can move it around and carry it without any problems.

7. What research do I need to gather about end user's needs and preferences?

The type of storage units user's prefer in terms of shape, size, special features.. The size they find ideal for a jewellery box and the colour scheme that is most preferred. I also must determine materials, manufacturing methods, use of standard components, fixings etc.

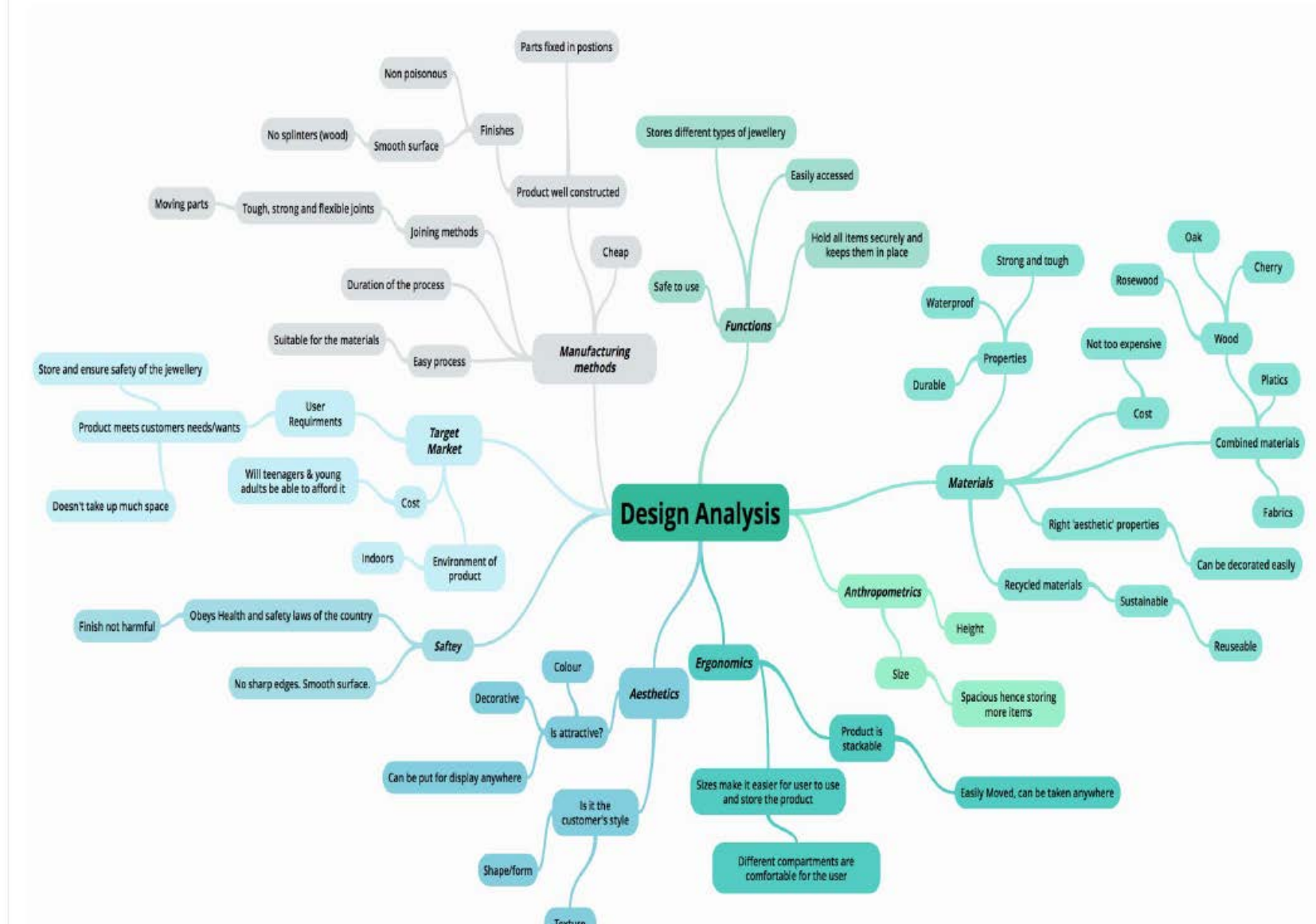

ANALYSIS OF PROBLEM

This black jewellery box costs 34.99 pounds. Height; 22 cm, Width: 26 cm, Diameter: 18.5 cm. This product has 4 layers of compartments which make it easy to classify your jewellery. It can be locked to and it looks like a small case where the user can take it with them while traveling.



This Amzdeal Black Jewellery box costa 19.99. Made of faux leather, medium density fiberboard, glass and flocked cloth. The size= 22.5 x 1.5x 13.5 cm. It offers the customer with various grids and drawers for classifying the jewellery, but the compartments aren't equally divided as in there are more compartments for rings than any other type of jewellery hence the users can't store that many jewellerys. It also comes with a lock.



This jewellery box on amazon costs 53.95. Size 26cm x 18.5cm x 16.5cm It has 3 pull out draws, 5 row ring cushion, earring tray and elastic pouch, it also comes with jewellery roll and a travel case when travelling. Having all the compartments designed for a certain type of jewellery makes it easier for the user to deal with and keep their jewellery safe. Customers have complained that it's a little pricey



I found this box on overstock.com. This costs MRY 412.68. Height: 5" Width: 12" and a depth of 9.5". This product is for people who don't possess a vast number of jewellery/ or not a large variety, suitable for males. Customer's review seems to be very positive. It has four compartments for watches, pen, rings and other two for any extras. It's made out of wood and fabrics. The only thing is that this box doesn't allow the user to store a vast amount/variety of jewellery for its price.



This box costs RM 65. With a height of 6.1cm and width of 16.9 cm. This serves as a jewellery storing unit, as seen in the photos there are no compartments which limits what the user can store inside it, since some types of jewellery can't be stored together or else they'll get damaged or tangled. Nevertheless this box can act as a decorative piece as it looks very antique. The user has to take care of the box and put in a place with the right conditions for the type of wood it's made of (rosewood).



This Sharman Jewellery box costs MRY 876.65. That price is very expensive, not many people will be willing to buy it. With its overall dimensions of: Height: 11", Width: 16.5" and a depth of 9.5". It has different compartments/drawers with different sizes which makes it very beneficial for storing different sized jewellery. There's a lot of room inside to store different types of jewellery. One thing about this storage box is that it isn't lockable. It's design and colour makes it look attractive just as an antique a lot of people have stated that in the review section, many others have stated that it fits very well with thier room decor.



What types of jewellery do you own? *

- Watches
- Rings
- Necklaces
- Chokers
- Bracelets
- Other: _____

Do you have a specific box for keeping your jewellery and other personal items? *

- Yes
- No

What problems do you often face when using with your jewellery box? *

- Handle isn't working properly
- Some parts (such as ring rolls) falling
- Trouble opening the lock
- It is not lockable/ secure
- Not an attractive design
- Other: _____

Do you have enough space to store all your jewellery? *

- Yes
- No

How much would you be willing to pay for a suitable jewellery box according to your needs? *

- RM 30-60
- RM 60-90
- RM 90-120

Select any 3 design factors that you look for when purchasing a jewellery box? *

- Can hold a lot of jewellery
- Must look very decorative, attractive with an appealing form
- Must have a reasonable price
- Must be decorative and appealing to look at
- Must have a reasonable size in which it won't require much space to store
- Compact and portable, suitable for traveling

What is the best height of the jewellery box? *

- 5-10 cm
- 10-20 cm
- 20-30 cm
- 30-40 cm
- Other: _____

Which of these boxes would you buy? *

- A
- B
- C
- D
- E



Do you have enough space to store all your jewellery? (21 responses)

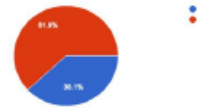

How much would you be willing to pay for a suitable jewellery box according to your needs? (21 responses)

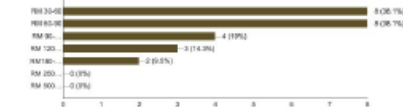

What materials do you prefer your jewellery box to be made from? (21 responses)

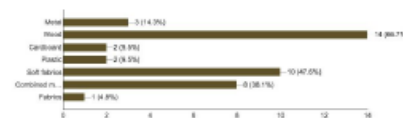

Select any 3 design factors that you look for when purchasing a jewellery box? (21 responses)

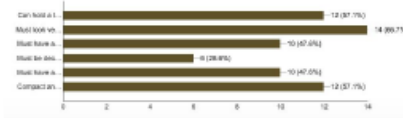

How old are you? (21 responses)

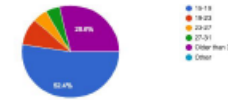

What types of jewellery do you own? (21 responses)

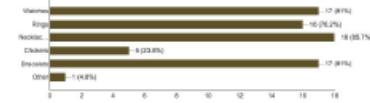

Do you have a specific box for keeping your jewellery and other personal items? (21 responses)

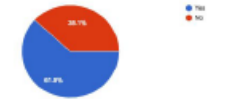

What problems do you often face when using with your jewellery box? (21 responses)

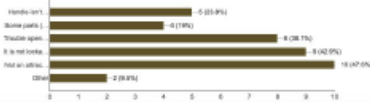

What is the best height of the jewellery box? (21 responses)

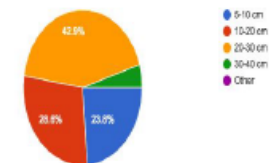



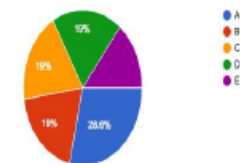

Which of these boxes would you buy? (21 responses)



Screenshots showing the questions and the result of the responses. This is so that I would get information about what the users need and prefer, such as what material the box should be made from, the problems they face when using a jewellery box. The answers would be used in order to make the product much more beneficial for the user by ensuring it meets the requirements. 38.1% didn't have a space/box to store all their jewellery. Problems faced: 47.6% stated that the design wasn't attractive, 42.9% agreed that the box wasn't lockable/secure. Others faced problems such as trouble opening it/ handle isn't working. Surprisingly only 23.8% are willing to pay over RM100 for a jewellery box, most votes were for RM30-90 76.2%. The preferred height for the box was 20-30cm with 42.9% of the response voting for it. It was evident that most people preferred their boxes to be made out of wood (66.7%), soft fabric (47.6%) & combined materials (38.1%)

These results will be very handy when designing the product, because it shows what the end user would be expecting from the product when it's purchased. Hence, specific measures should be taken in account to ensure that the customer won't face problems when interacting with the product, such as ensuring that the product can be locked and secured, the design is attractive. It will also help when writing the product specifications, making them more accurate.

Materials	Properties	Reasons for choosing
<p><u>Oak</u></p> 	<ul style="list-style-type: none"> ○ Very strong, durable ○ Finishes well, open - grained ○ Expensive (disadvantage) 	<p>It's very durable and strong meaning that it'll last for long. It might be a little bit hard to work with and it is a little but expensive. It finishes well and its natural colour makes it suitable for the product.</p>
<p><u>Cherry</u></p> 	<ul style="list-style-type: none"> ● Stiff and strong ● Fine, closed-grain ● Elastic 	<p>It's hard and resilient meaning it will last for long time. It's elastic and quite easy to work with, even though it's subject to shrinkage but after drying it won't be. It can be easily cut and carved as well as bent.</p>
<p><u>Walnut</u></p> 	<ul style="list-style-type: none"> ● Hard and resilient ● Subject to light shrinkage ● Heavy 	<p>It is very easy to work with walnut wood both with hands tool and power tools. It is an ideal wood for carving and woodturning. There isn't much movement which means that joints have a higher chance of staying tight. It finishes very well, an extremely smooth final product can be accomplished by polishing the wood. Although it has good strength and durability it can get affected when exposed to the weather.</p>
<p><u>Brass</u></p> 	<ul style="list-style-type: none"> ● Strong ● Ductile ● colourful 	<p>It would be good for making the handles/knobs of the box, as it's relatively easy to shape/ cast, it is not that expensive. Corrosion-resistance It also has a nice colour which will add to the looks of the box. It can also be used for the hinges.</p>
<p><u>Stainless Steel</u></p> 	<ul style="list-style-type: none"> ● Cheap ● Corrosion resistance ● Attractive 	<p>The hinges would be of this material as it's rust resistance and has many other corrosion resistance properties meaning that it would last very long. It's cheap, easily available and it's safe and easy to work with as it is easily shaped.</p>
<p><u>Velvet (cotton)</u></p>	<ul style="list-style-type: none"> ● Strong/natural sheen ● Very durable ● Soft texture 	<p>Velvet has a very smooth texture and is usually used for lining the inside of jewellery boxes. Cotton is natural and contains no chemicals meaning that it would not harm the jewellery unlike other fabric that would tarnish silver jewellery. It's very durable and strong, yet the user would have to clean it carefully.</p>
<p><u>Suede</u></p>	<ul style="list-style-type: none"> ● Soft ● Pliable ● Napped fabric 	<p>This would be suitable to make an upholstering surface for the compartment. It's very soft and absorbent, its pliability makes it suitable for delicate uses and it's quite durable. It's less expensive than full grained leather. By covering the inside lining of the jewellery box compartments, it will be ensured that the jewellery will be safe and protected against scratches as they will cushioned.</p>
<p><u>Cotton flannel</u></p>	<ul style="list-style-type: none"> ● It's lightweight ● Has enough pile to cushion ● Soft and smooth to touch 	<p>This would be suitable to line the inside of the jewellery box. It's soft, smooth and breathable. It's quite thin, but it has enough pile to cushion the jewellery. It doesn't contain any harmful substances/ chemicals that would tarnish fine jewellery.</p>

Dovetail joint

This joint was chosen as it is very suitable and durable joint. It is a very strong joint and it is almost impossible to be pulled apart. This joint will be used to make the base of the box; link the sides to the front. And join the drawers together.



Kerfing

Kerfing is a process used to curve wood, used to bend quite thick pieces of wood. A series of cuts across the grain are used to form the inside of the curve. This method can be used for curving the edges of the body (the back of the box) to reduce the number of sharp edges of the box. There might be a risk of the wood on the outside splitting if the spacing and depth of the cuts aren't calculated carefully.



Lamination

Lamination is a method used to bend wood by applying force on veneers of wood to create a curve. This method creates tight curves with lower risk of splitting the wood during/after the process is done. This method can be used to bend/curve the lid of the jewellery box.



Flocking

It's a manufacturing process in which flocks (fabric particles) are applied directly onto the material, it is used to increase the aesthetics, colour and texture of the product it's been applied on. This method could be used to cover the sides inside the box with flocks of the desired fabric.

Drilling

This manufacturing method will be used to drill holes on the jewellery box, such as drilling the holes for the screws. It will also be used to drill holes so that a circular pivot (rod) can be used to hold the compartments on top of each other.

Wood carving

Carving is a woodworking process in which a shape/figure is drawn onto the wood surface and then the shape is carved. This method can be used for designing the lid of the box/ one side of the box, to make it look more attractive and antique. Soft and closed grain woods are preferred for this process to ensure the wood won't break accidentally.



Hinges

Hinges are mechanical bearings between two solids to allow rotation between them. This method isn't that hard to make and not very time consuming. This would be used to join the body/base of the box together with the lid, to allow the user to open and close the lid easily.



SUB HEADINGS	SPECIFICATIONS		The joints/ compartments should tested for their stability and strength to ensure the product is of a high quality.
Purpose	The product will store the most common types of jewellery people own. Can be placed on flat surfaces.	Safety	The edges should be smoothed so that the user won't get injured accidentally.
	It saves space by having compartments for different types of jewellery with different sizes.		The metallic parts (such as knobs and hinges) should last for a long time without rusting.
	The customer will be able to take the product with them when travelling.		The box will be tested for it strength and stability of the compartments.
	The product should protect the jewellery from being damaged.	Cost	The final product should cost RM 90-120
Target Market	Young adults	Environmental Factors	The product should withstand humid environments.
Aesthetics	The product must be attractive, this can be done by crafting on the wood with simple patterns/shapes.		The wood and metal should not rot or rust easily.
	Dark coloured wood will be used, so that the product will go well with the surroundings.	Ergonomics	Joints should be well built and strong. Nails/screws have to be secured properly, to prevent injury.
	The knobs should be decorative.		It has to be ensured that the edges aren't sharp so that the user won't be injured while using the product.
Materials	Mostly made out of wood that is strong, durable and has a suitable colour (eg. Cherry, Oak).	Manufacturing Methods	The manufacturing methods must be suitable for the materials chosen.
	The inside of the compartments has to be covered in a material that would ensure the jewellery stay safe undamaged.		Joining methods, wood carving, wood bending are some manufacturing process that will be suitable to make the product.
	Brass would be used to make the knobs, it is very easy to shape/ cast and it's going to add more colour to the product.		
	The materials must lightweight as well, so that it would be easy to carry the product.	Form	The product should have an appealing and attractive form.
	The material covering the inside of the compartments should be soft and protective.		The shape of the product should be unique. The shape/ arrangement of the compartments should match with the whole unit.
Manufacturing Time	The box will take approximately 16-20 hours to be manufactured.	Equipment and tools	Machines: sanding machine Hand tools: hammer,
Quality Assurance	This should be carried out to ensure that all parts of the box are functioning well, ensure that all moving" parts are moving smoothly and with no problem.	BSI standards	

JUSTIFIED PRODUCT SPECIFICATIONS

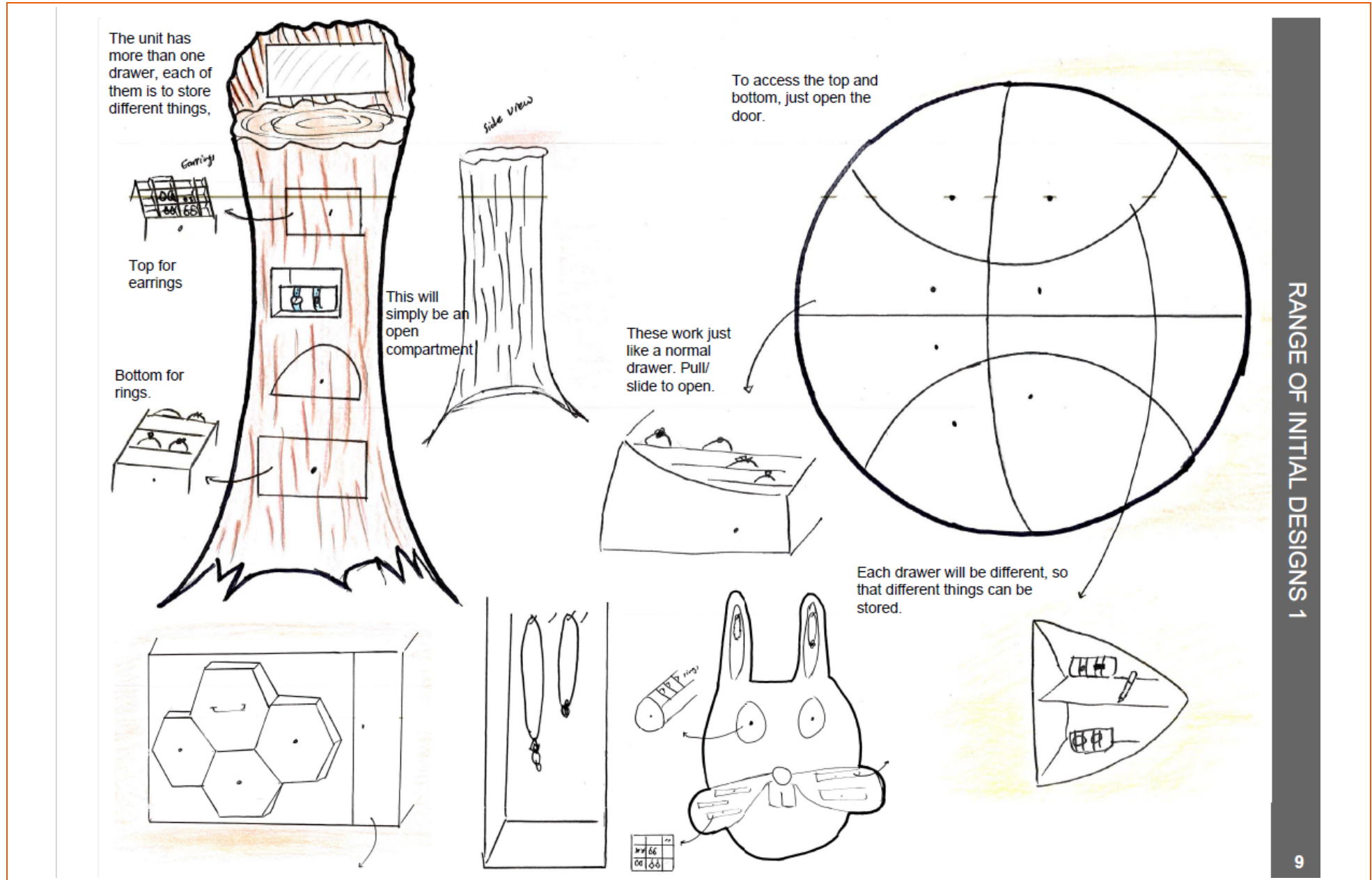

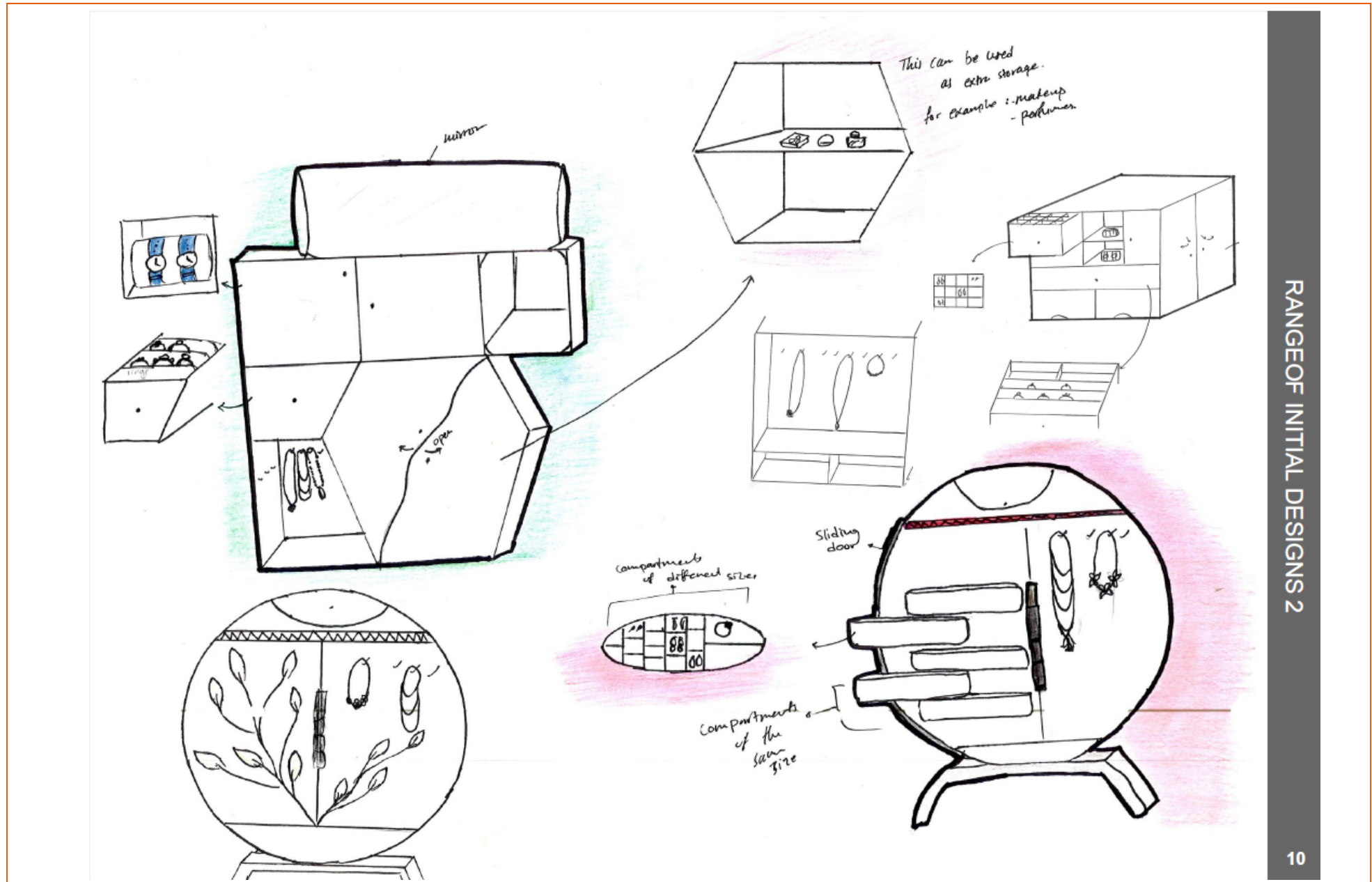

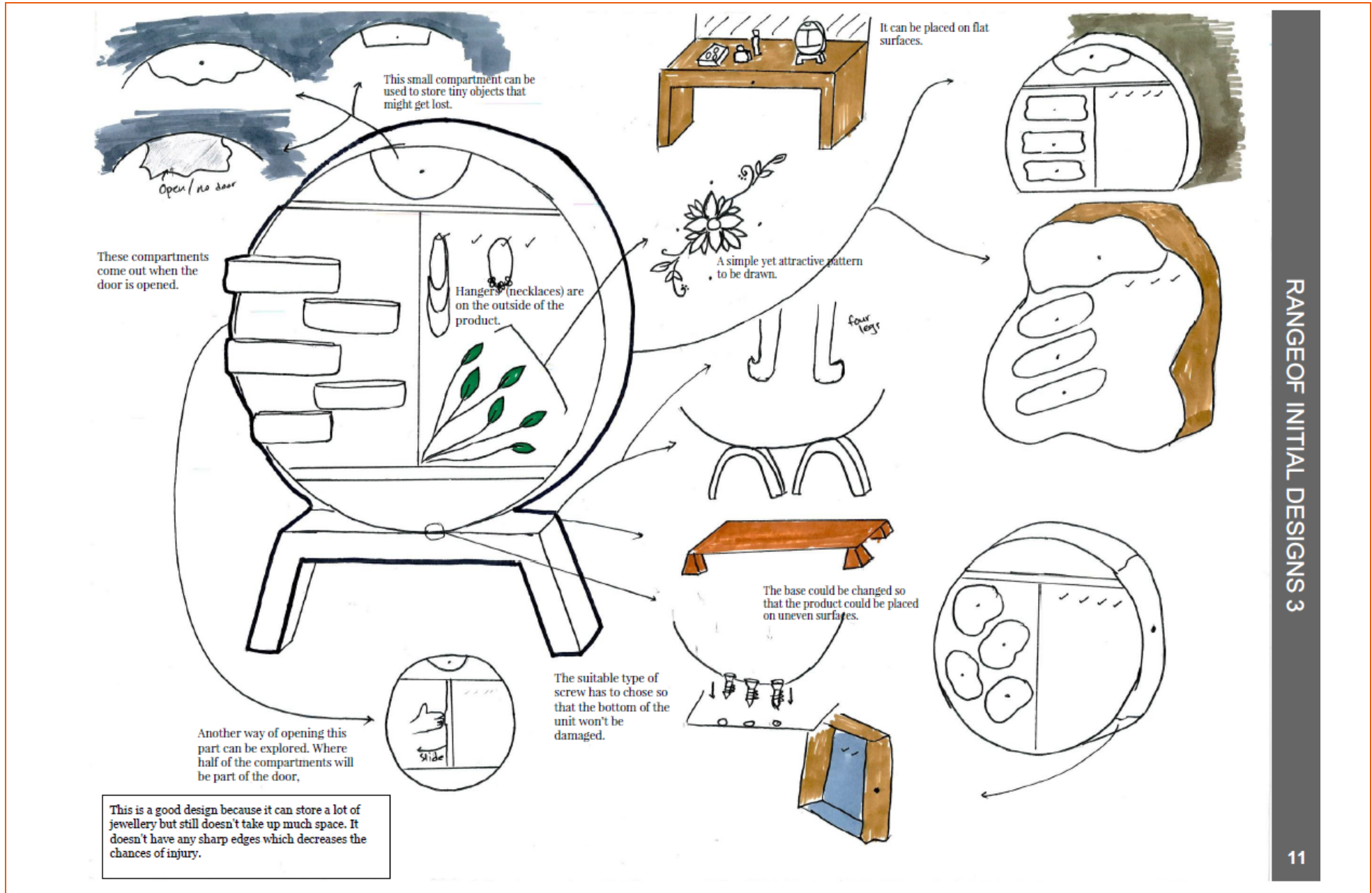

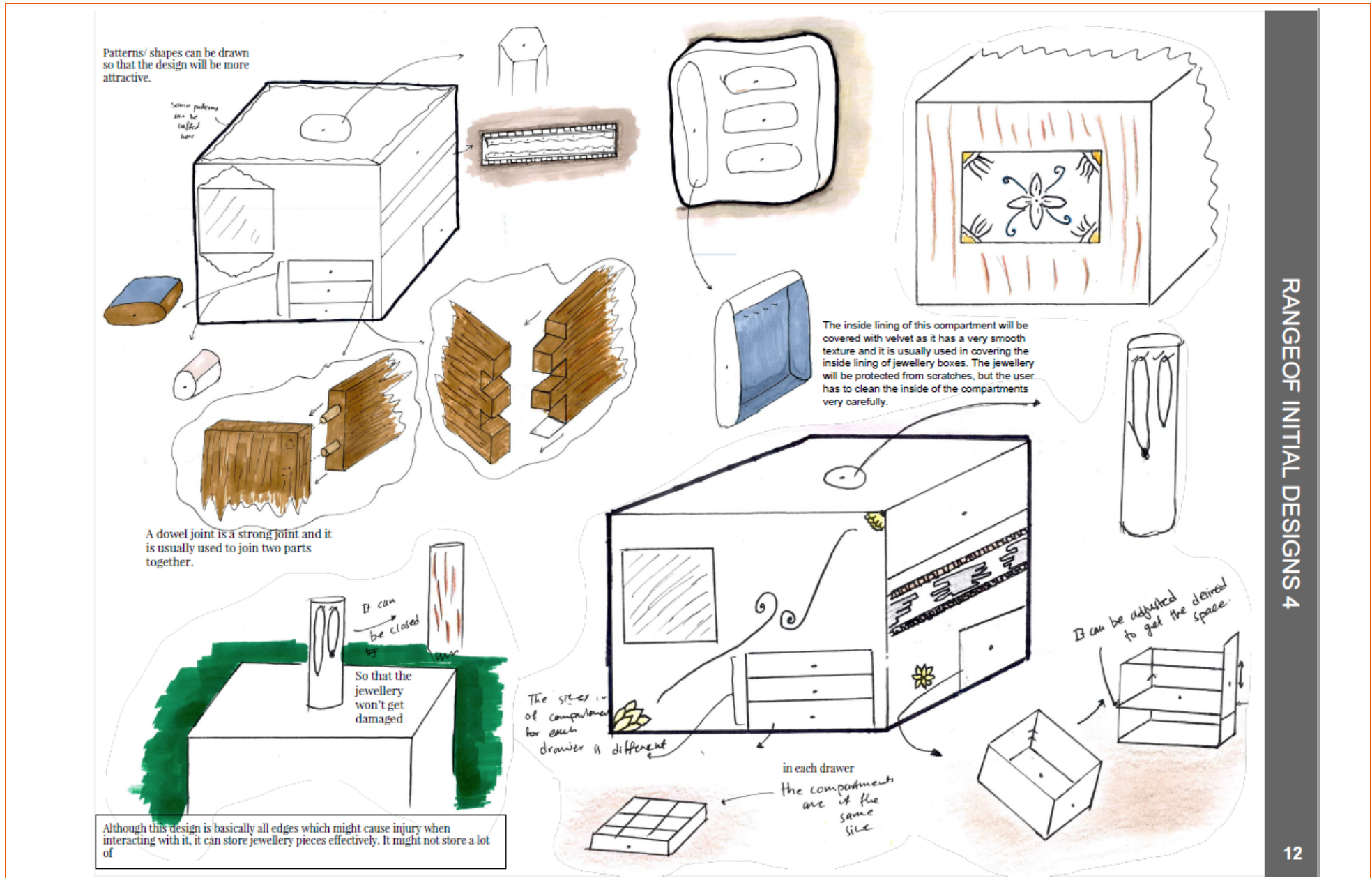

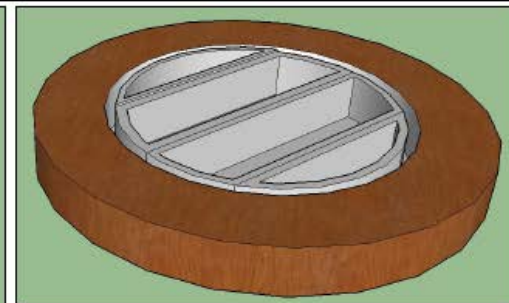
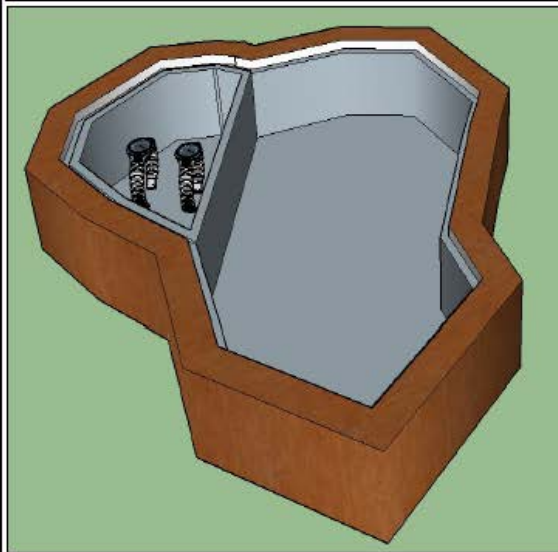
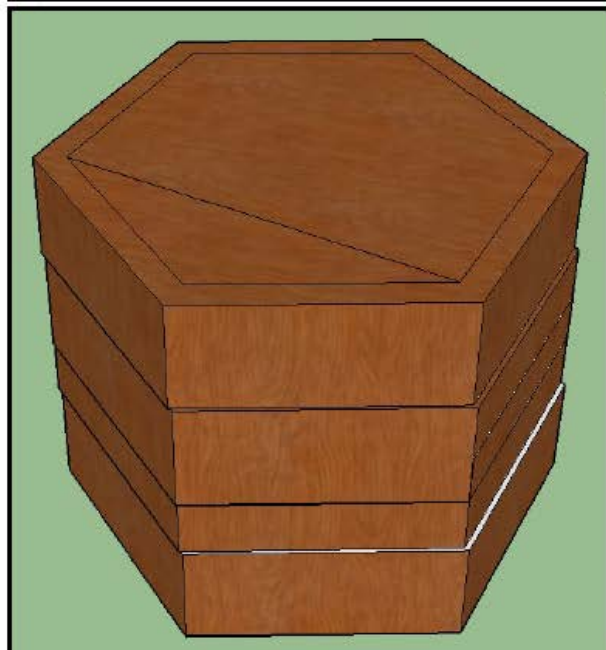
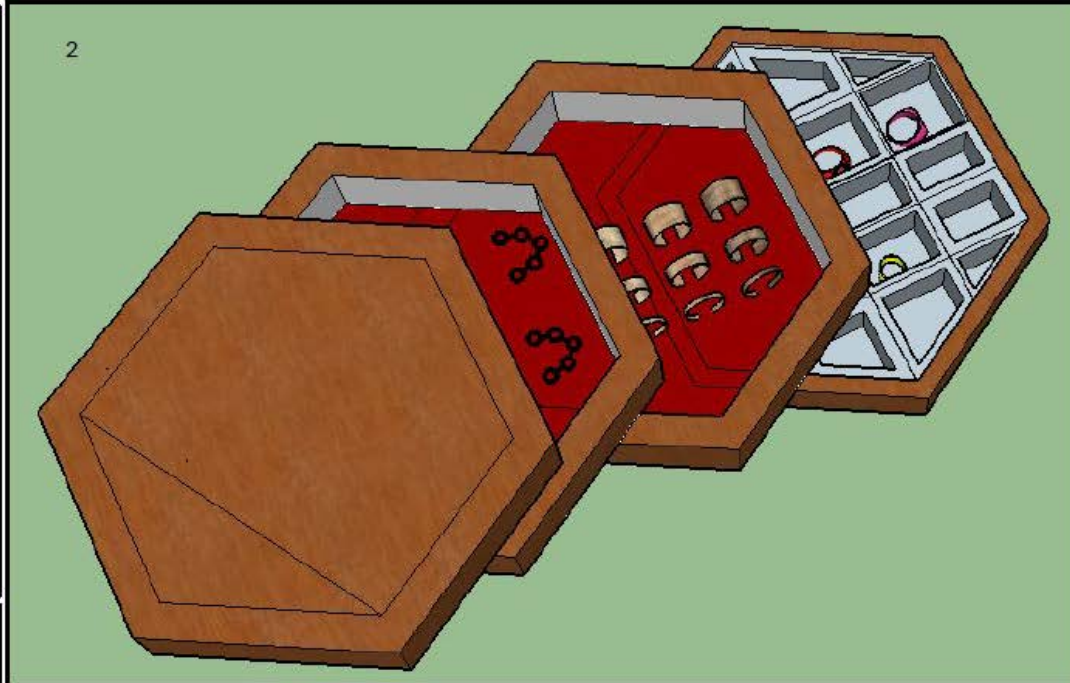
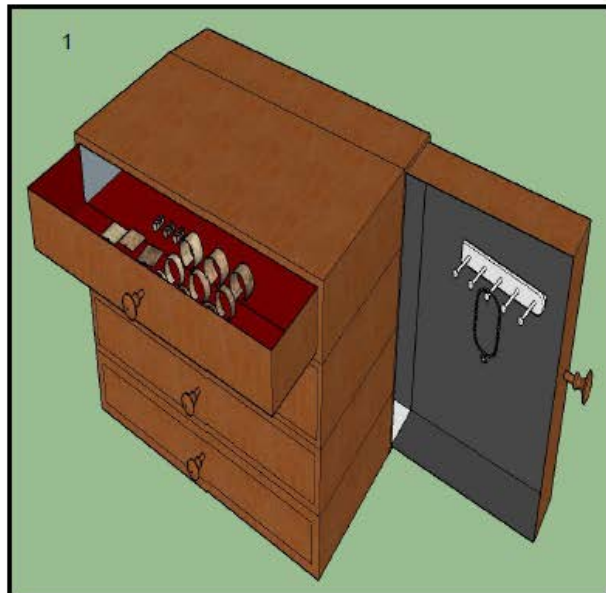

- 1) This design consists of drawers to store the user's jewellery. Each drawer can be used to store a different kind of jewellery. It also has a long drawer at the back of the unit which can be used to store necklaces.
- 2) The design benefits the user in a way that they can store a variety of different jewellery while not taking up space as the compartments are stackable.

INITIAL DESIGNS EVALUATION		1	2	3	4
ASSESSMENT CRITERION OF PRODUCT SPECIFICATIONS					
1	There are different compartments for different types of jewellery.	2	3	2	3
2	It saves space and holds most if not all of the jewellery the user owns.	2	4	1	3
3	There should be no sharp edges. The nails/screws are secured properly.	3	2	2	2
4	The joints are strong and suitable.	2	3	3	3
5	Moving joints/ compartments are strong and easy to move.	3	3	3	3
6	Handle/ knobs should be secured and properly positioned in place.	3		2	3
7	The product has a natural colour or dark. It has patterns to make it look more attractive.	3	4	3	2
8	It can be placed anywhere and easily moved/ taken away with the user.	3	3	2	3
9	The surface finish is attractive and it doesn't change the natural look of the wood.	2	4	2	2
10	The product shouldn't take much space, rather it saves space.	3	3	3	3
TOTAL SCORE /100		27	29	27	27

DESIGN 1	
STRENGTHS	<ul style="list-style-type: none"> It has a round shape and not the usual "boxy" shape expected. There are a number compartments A natural dark colour and not too many patterns carved.
WEAKNESSES	<ul style="list-style-type: none"> It might not be stable/ the base isn't suitable, a better joining method has to be chosen. Only a small range of jewellery can be stored in this product.
DESIGN 2	
STRENGTHS	<ul style="list-style-type: none"> It can hold a wider variety of jewellery. Patterns/shapes carved make it look more appealing.
WEAKNESSES	<ul style="list-style-type: none"> The space isn't sufficiently used; the arrangement of the compartments should be changed. The shape isn't unique, very common and expected.
DESIGN 3	
STRENGTHS	<ul style="list-style-type: none"> It doesn't take up much space, as it is stackable/ has moving parts. The shape isn't very usual. Each compartment is used for a specific type of jewellery
WEAKNESSES	<ul style="list-style-type: none"> The no. of compartments isn't enough to store more/ wider variety of jewellery. It has a lot of edges which might cause injury to the user when he/she is interacting with it.
DESIGN 4	
STRENGTHS	<ul style="list-style-type: none"> It doesn't take up much space It has different compartments to store different jewellery. It has a compartment specially for keeping necklaces
WEAKNESSES	<ul style="list-style-type: none"> It doesn't have a unique shape, it's the mainstream rectangular box. The design has lots of sharp edges, the user might get hurt/ injured.

REVIEW OF INITIAL DESIGNS

AREAS TO IMPROVE ON/DEVELOP FURTHER

- Make sure that there are enough compartments for different types of jewellery.
- Decide on the specific materials that are going to be used for different parts.
- Ensure that the type of joint chosen is suitable for the moving part and that it's strong.
- Try to make the product save as much space as possible.
- Make sure that the product will safely store the pieces of jewellery.
- The stages of manufacturing the product, and the methods for some parts of the product.
- Ensure that the product won't cause injury when the user is interacting with it; edges shouldn't be very sharp.
- Develop the patterns that are going to be drawn on the product, ensure that they look appealing and suitable.
- Work out how the moving parts are going to be joined and how they work. Choose a suitable and strong joint.
- Choose a better base for design 1.
- Ensure that the arrangement of the compartments is suitable so that the whole product works as one unit.

SELECTED DESIGN IDEA: DESIGN 1

I choose this design because it got the highest score in meeting the product specification. This design doesn't have a square/boxy shape. The form and shape of this design can be developed further to ensure that : 1- its shape is quite unique. 2- It's going to save space (stackable compartments; moving compartments). This design can keep a wider variety of jewellery types, each having a separate compartment. It has simple patterns carved on it to make it more eye-catching. The surface finish will not cover/ change the natural look and colour of the wood/ materials; this is going to make the product look of a higher quality.

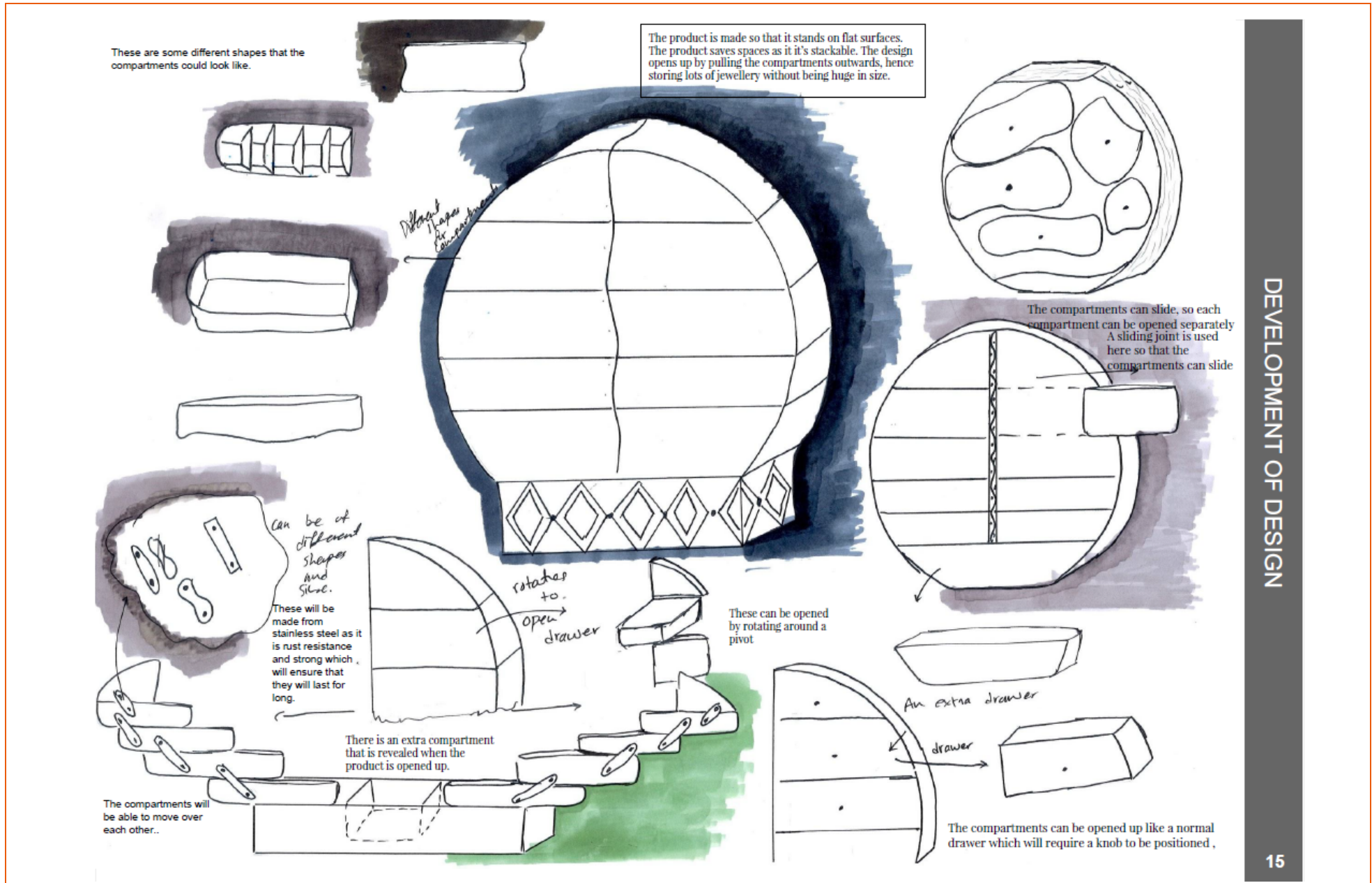

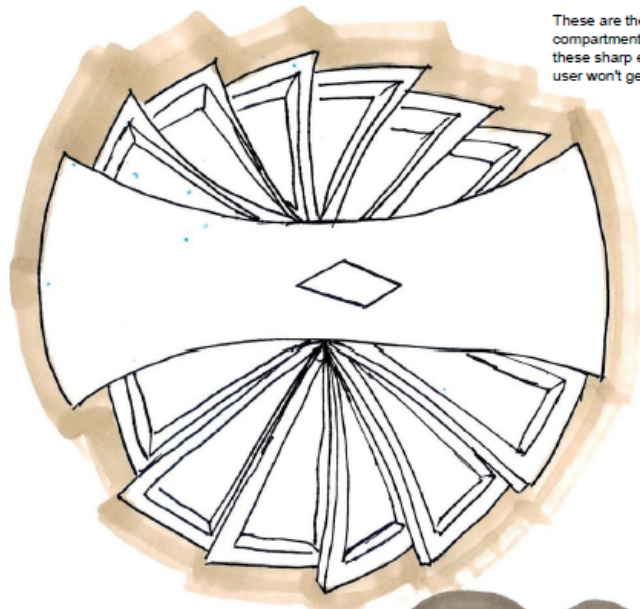

These are the other shapes that were explored as the shape of compartments for the whole product. They might have sharp edges but these sharp edges can be rounded a little bit or smoothed so that the user won't get injured when interacting with the unit.

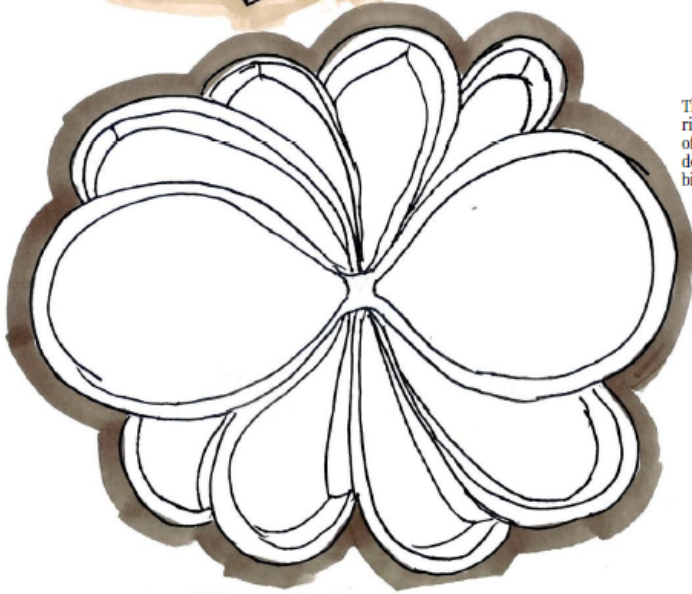
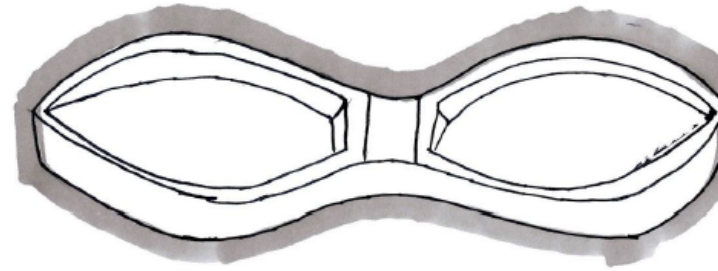

The shape of the product has no sharp edges, which means that risk of injury is reduced. The product has lots of compartments of which each is used to store a specific type of jewellery. The design has got some patterns on it which makes the product a bit more appealing.

DEVELOPMENT OF DESIGN

The compartments are stacked on top of each other on a rod which will hold them in place and become the pivot each compartment rotates around. Each section (compartment) rotates around to open up.

Cherry wood can be used to make the compartments as it hard and resilient; ensuring that it will last for long. It is also easy to work with as it is easily cut, armed and bent.

The product has 6 units of which each has 2 compartments, this ensures that the user can store almost all their jewellery. Some compartments are designed to store a specific type of jewellery.

Each compartments can be removed separately as they're not stuck together rather the compartments are stacked on top of each other.

This design is easy to interact with and ensures that the user can reach and access their stored jewellery easily. The product doesn't have any sharp edges which reduces the chances of injury to the user while they're interacting with the product. The shape of the design isn't very usual. The whole unit is moving (for the compartments to open up they have to be rotated).

A hole will be cut off so that the compartments can be placed around the rod/pivot so that they will rotate around it.

DEVELOPMENT OF DESIGN

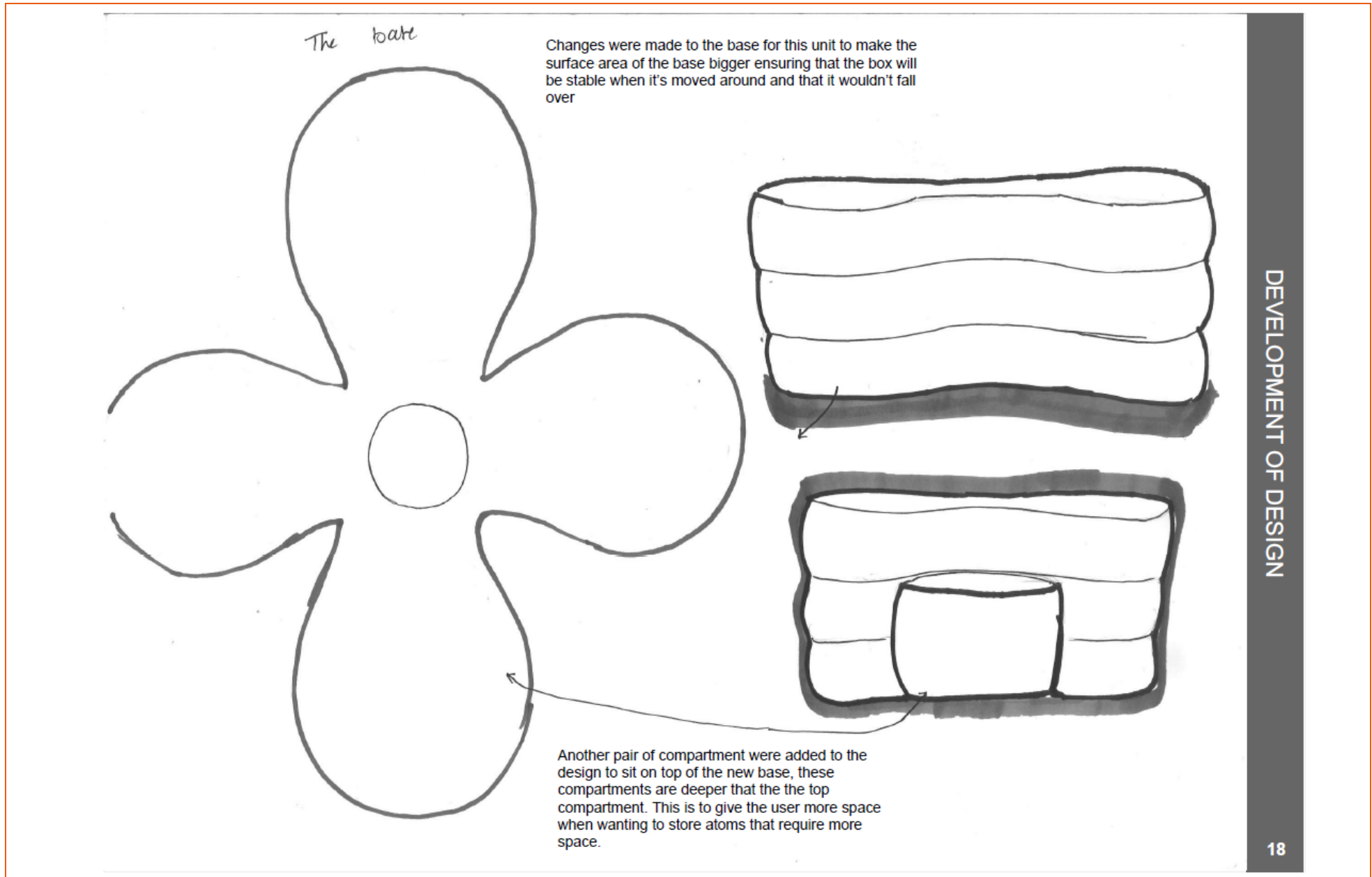

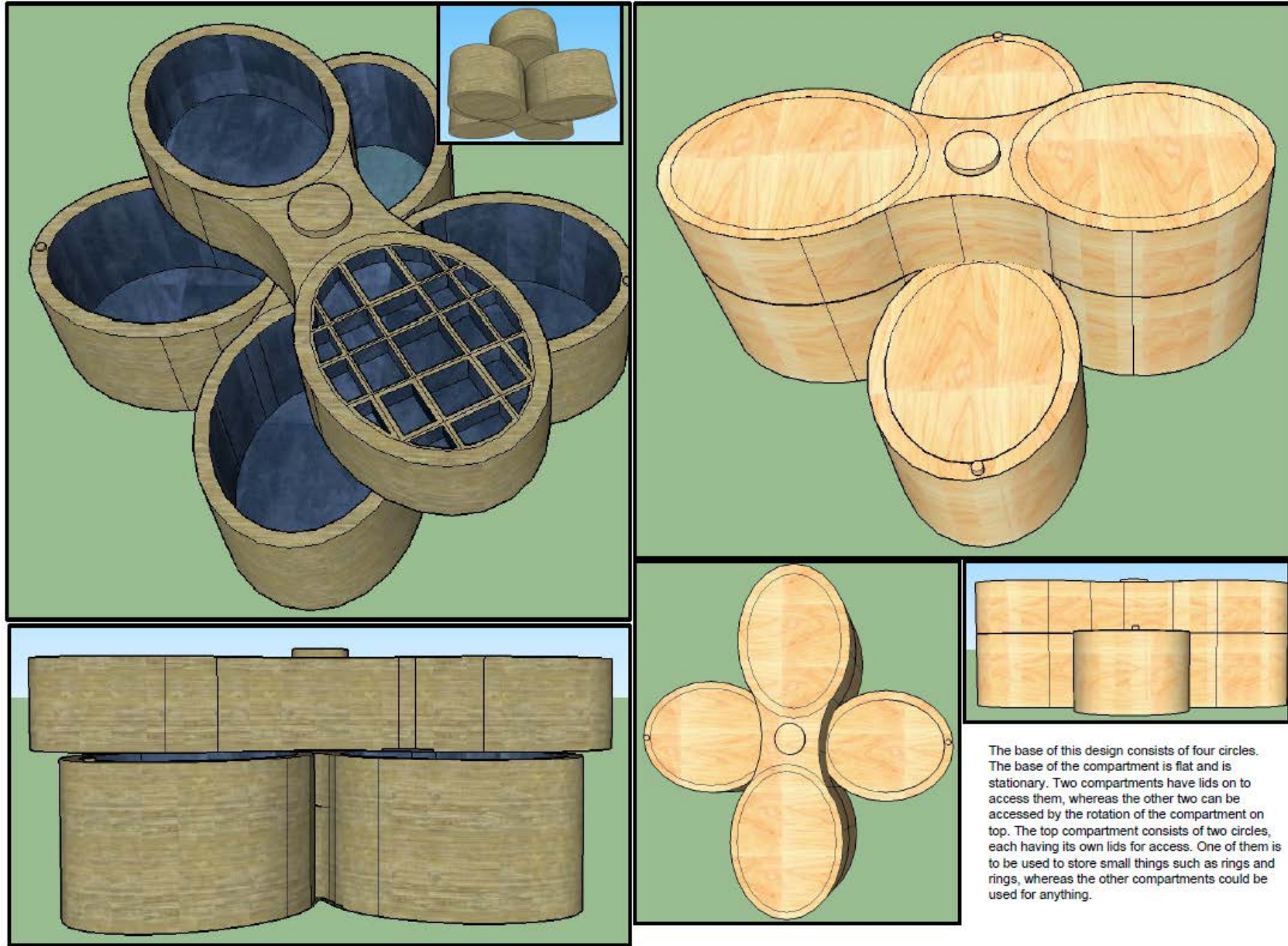

The base of this design consists of four circles. The base of the compartment is flat and is stationary. Two compartments have lids on to access them, whereas the other two can be accessed by the rotation of the compartment on top. The top compartment consists of two circles, each having its own lids for access. One of them is to be used to store small things such as rings and rings, whereas the other compartments could be used for anything.



The product is to be placed on flat surfaces. As it's a jewellery box, it can be placed on a dressing table.

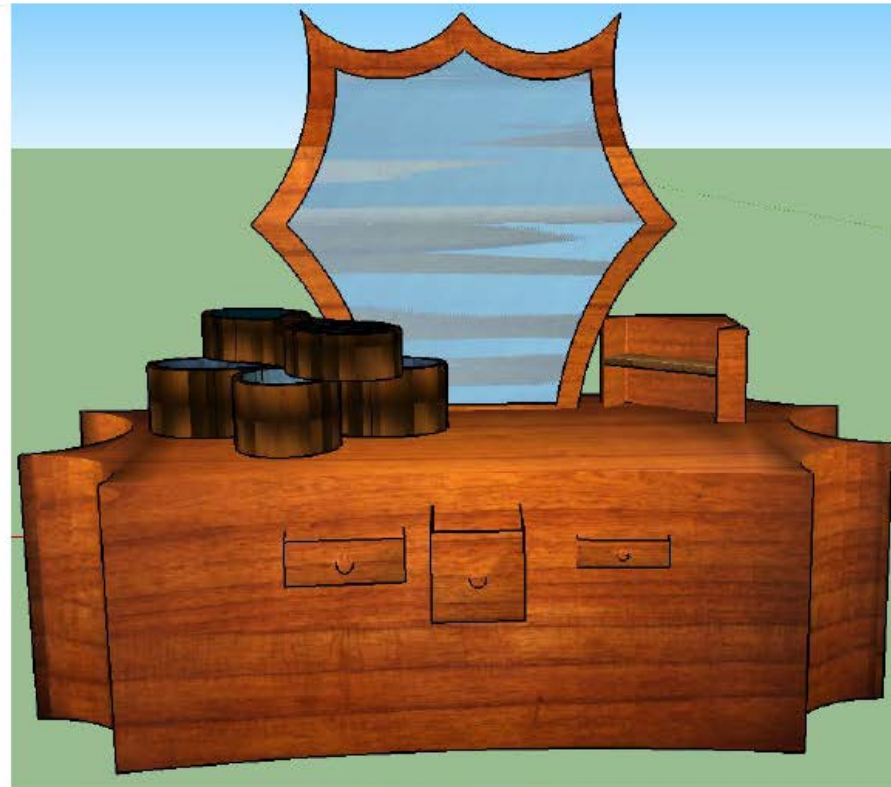

The user can place the product at home and place it on any table around the house. As the product is not heavy, the user will easily be able to move the product around and place wherever they want.

SUITABLE ENVIRONMENTS FOR MY PRODUCT



The first thing to do was to mark out the outline of the compartment onto card, cut and use it as a template to mark out the shape onto styrofoam. After marking it out onto styrofoam, the shape was cut out using a hot wire foam cutter. After that, the base of each compartment was glued on to the body using PVA glue.

The hole was marked out to be exactly in the middle so that a wooden rod would be inserted to act as the pivot of rotation for the compartments. The length of the rod needed was taken and 2 cm extra were added, then a wooden rod was cut.



To test if the model was working, after the rod was inserted the compartments were then rotated 360 degrees except for the bottom compartment as it had to be stationary. The top compartments rotated very well without any problems.

But as all the compartments had the same depth, it was decided to try and change the design a little bit by having one of them deeper. This was done by combining the bottom two compartments together. Since that happened, the number of compartments decreased, so the base of the compartment was altered so that the base would consist of 4 compartments.



After all the changes were done, the only part that would rotate was the top compartment as the compartments at the base didn't rotate. The design now has 4 deeper compartments and two that stayed the same depth.



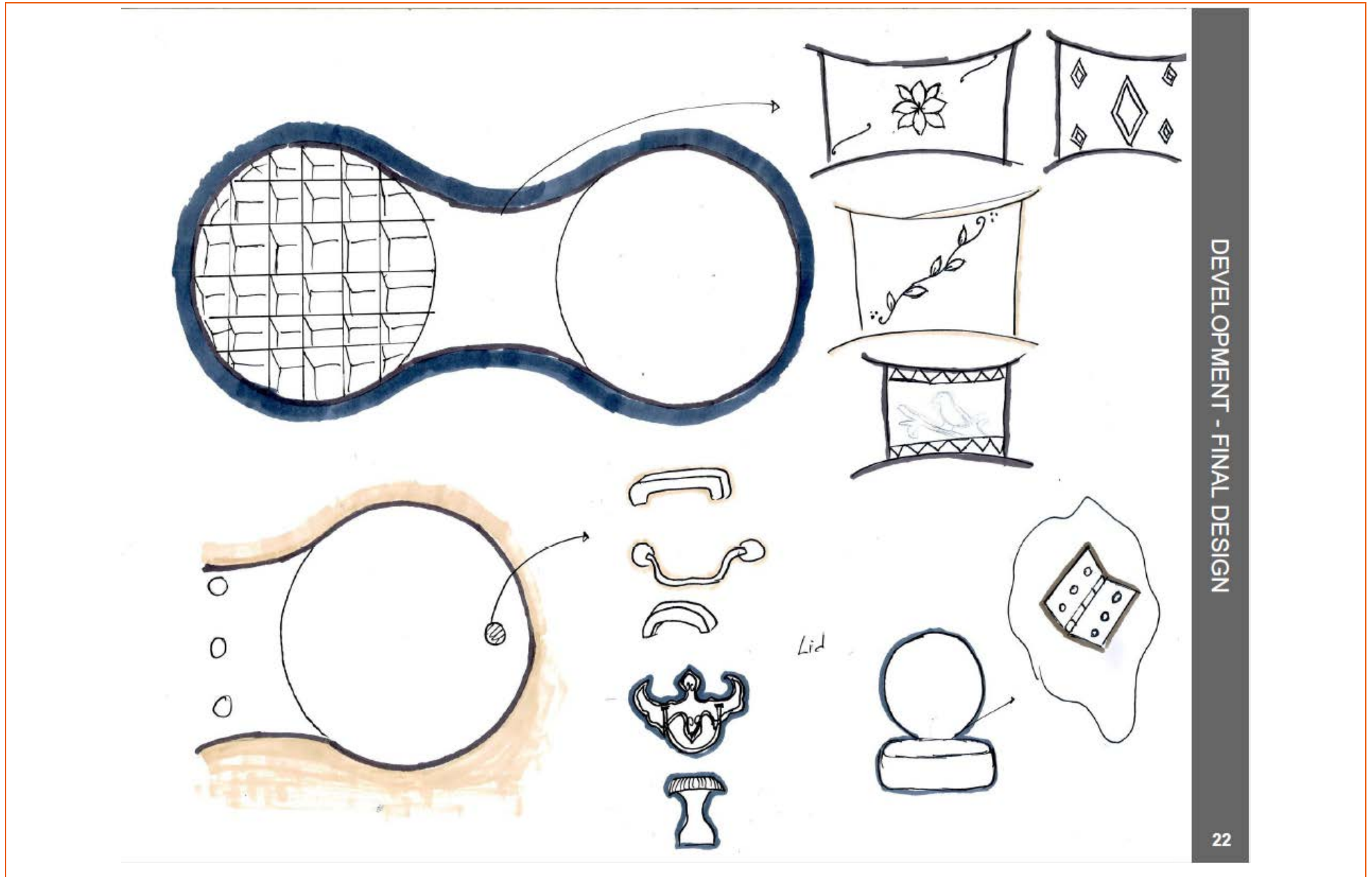

DEVELOPMENT - FINAL DESIGN

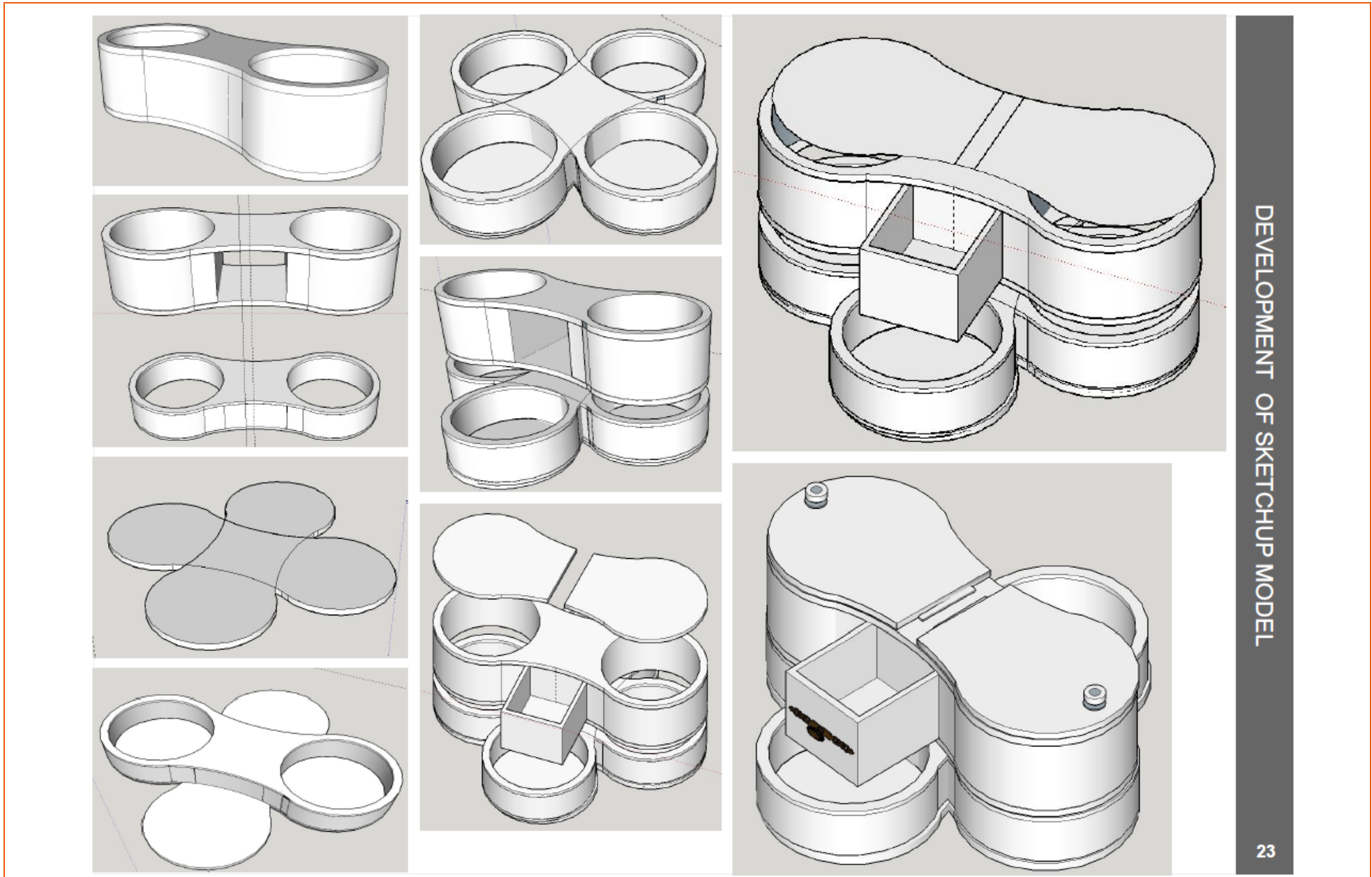

DEVELOPMENT OF SKETCHUP MODEL

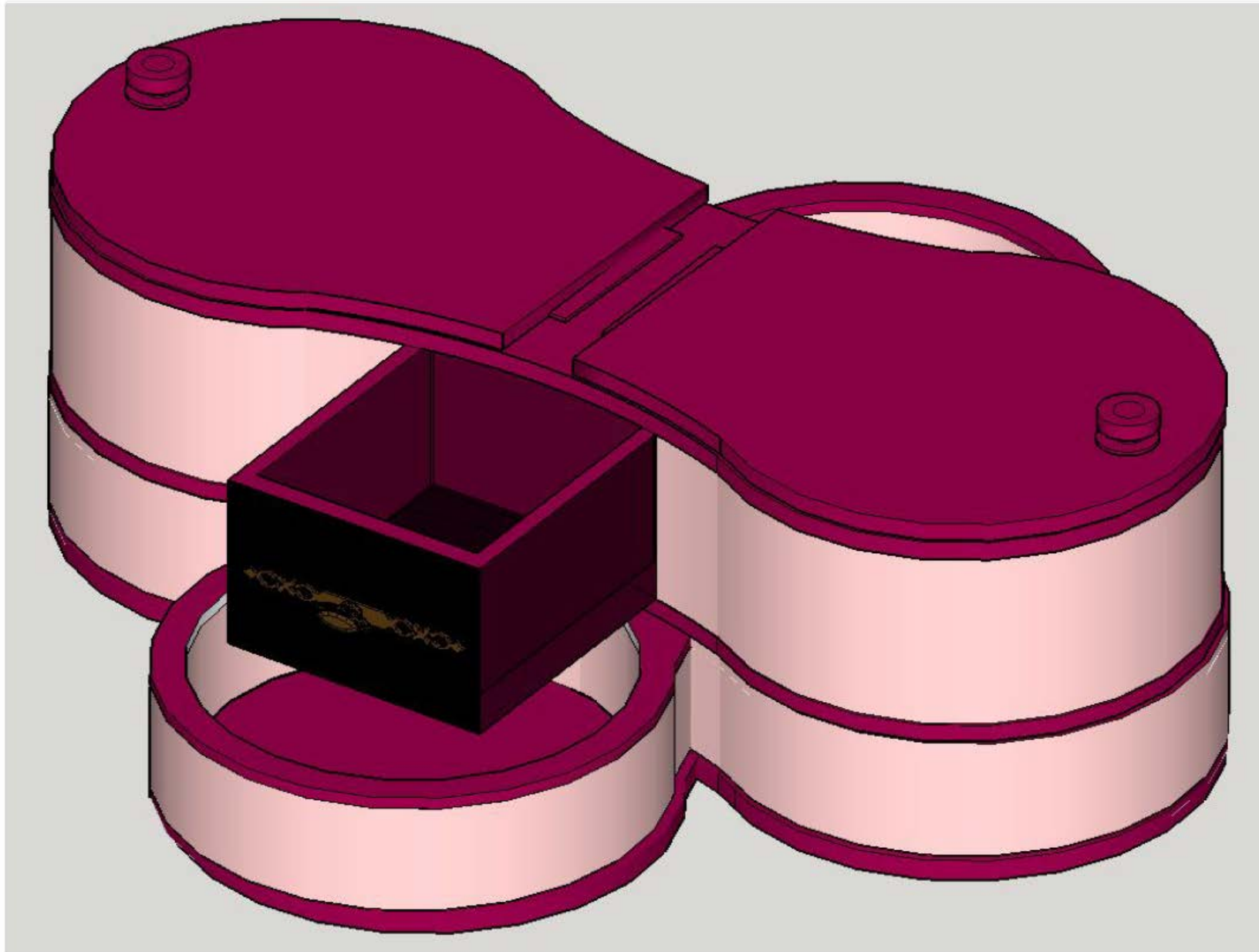

DEVELOPMENT - PRESENTATION DRAWING

24

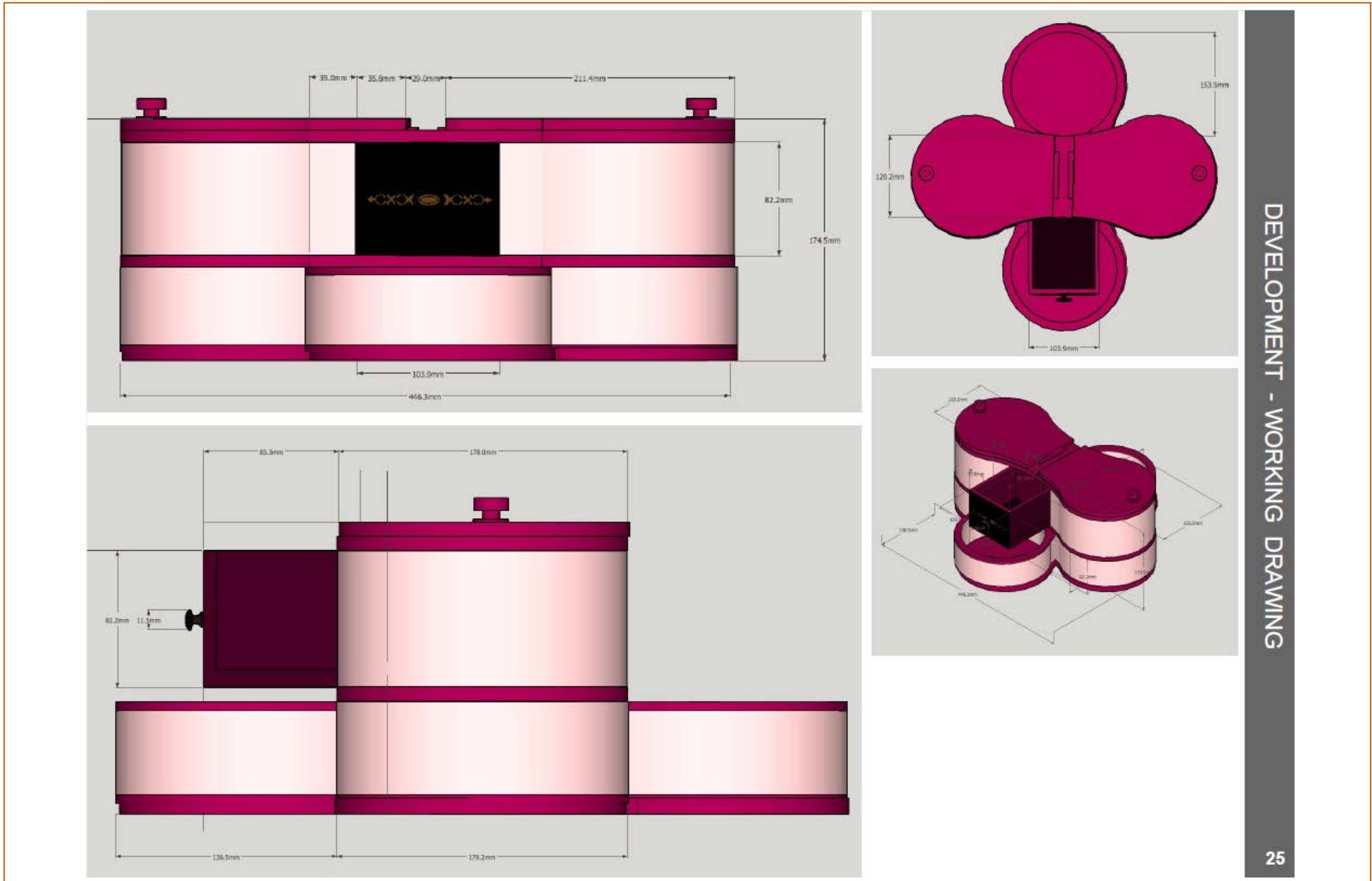

Sketch one

Sketch two

Sketch three

1

2

3

6



Name	Length, Width, thickness
1 Top compartment	450, 150, 55
2 Bottom compartment	450, 150, 100
3 Side compartments	150, 150, 100
4 Lid for side compartment	150, 150, 5
5 Lid for top/bottom compartment	450, 150, 5
6 Base	450, 450, 5

PLANNING FOR PRODUCTION

26

No.	CUTTING LIST	SIZES IN MM				No. of pieces	TOL +/-	ADDITIONAL INFORMATION
	Name of part	Chosen material	L	W	T			
1	Top compartment	plywood	450	150	50	1		The outline of the shape will be drawn out onto pieces of plywood 10mm thick. 2 circles: diameter of 150mm connected together and are 150mm apart, then they'll be cut out then a circle with a diameter of 130mm will be cut out from the inside of the 2 bigger circles. The first piece that was made can be used a template to mark out more layers so that they will be glued on top each of other to get the desired thickness of 50mm. The edges of this unit will be smoothed. The surface will be varnished.
2	Bottom compartments	Plywood	450	150	100	1		This compartment will be cut out the same way as the previous one using the template that was made previously, the only difference is the thickness of this compartment. This compartment is going to be 100mm thick instead of 50mm thick. The surface of this unit will be varnished.
3	Side compartment	Plywood	150	150	100	2		2 circles inside of each other will be marked out onto a piece of plywood. The first will have a diameter of 150mm and the inside circle will have a diameter of 125mm. The same processes/steps that were taken to make the first 2 compartments will be used to make this one. The desired thickness for this compartment is 100mm. This will be repeated twice to get two compartments. This surface of this compartment will be painted with a different/darker colour and then it'll be varnished.
4	Lids for side compartments	Plywood	150	150	5	2		2 circles with a diameter of 150mm will cut out of a piece of plywood that is 5mm thick. The lids will have some
5	Lid for the top compartment	Plywood	450	150	5	1		Using the template that was made before, mark out the shape on a piece of plywood that is 5mm thick. The circles will have to be cut out, so that there will be three parts, 2 circles and the a piece that connects them.
6	Base	Plywood	450	450	5	1		Using the template that was made before, mark out the shape horizontally into a piece of plywood that is 5mm thick. Repeat this by marking out the shape on top of the previous one vertically so that the intersect from the middle. Then cut out the outline of this shape off the plywood.

Selection of Materials			
	Material	Reason for Selecting	Photo of Material
1	Plywood	It's easily available and it is very durable. It can come in different sizes which makes it easy to get the desired thickness for the product.	

Selection of Manufacturing / Joining Methods			
	Manufacturing Method	Reason for Selecting	Photo of Method
1	Using PVA to glue the pieces of wood together.	PVA glue is mostly used to join pieces together. It ensures that the pieces of plywood together and giving it more strength.	
2	Using contact adhesive to glue the fabric onto the inside lining of the compartment.	Contact adhesive is the glue that is used for joining fabrics. It ensures that the fabric stays glued to the wood for a long period of time.	

PART 1: Top compartment							
Short Description of Manufacturing Process	Materials	Tools & Equipment	Risk Assessment (Health & Safety)	Quality Control Checks	Estimated Making Time	Actual Making Time	Key Modifications Made & Why
Measure and mark out the shape of the top compartment	Plywood	Pencil, compass, steel ruler			15 min	15 min	
Use the piece that was cut as template to mark out more than one pieces to be cut. Glue the pieces of plywood on top of each other to get desired thickness.	Plywood	PVA glue		Ensure that the pieces line up together and fit perfectly.	30 min	40 min	Instead of using plywood and gluing more than one piece together, I used high Impact Polystyrene (HIP) to make the hollow space of the drawer.
Smooth out the outside and the inside lining of the compartment.	Plywood			Make sure that not too much wood was removed.	15 min	25 min	
Measure and mark out onto fabric the insides of the compartment	Fabric	Marker pen, steel rule, compass			20 min	10 min	As the inside of the compartment is now there was no need to cover the whole inside lining, instead the base of the compartment had to be covered as it's wood.
Mark out a base for the compartment and glue it on.	Plywood	Pencil, Araldite glue		Ensure that the glue dries fully without being moved around.	25 min	20 min	
Glue the fabric onto the walls of the insides of the compartment.	Fabric	Contact adhesive		Make sure that the fabric is glued perfectly onto the walls.	20 min	15 min	
Mark out the lid for the compartment	Plywood	Pencil			15 min	20 min	
PART 2: Bottom compartment							
Measure and mark out the shape of the side compartments onto plywood.	Plywood	Pencil, steel ruler, compass			10 min	10 min	
Use the piece that was cut as template to mark out more than one pieces to be cut. Glue the pieces of plywood on top of each other to get desired thickness.	Plywood	PVA glue		Ensure that the pieces line up together and fit perfectly.	30 min	40 min	Instead of using plywood and gluing more than one piece together, I used high Impact Polystyrene (HIP) to make the hollow space of the drawer.
Smooth out the outside and the inside lining of the compartment.	Plywood			Make sure that not too much wood was removed.	15 min	20 min	
Measure, mark out and cut out fabric for the inside lining of the compartment.	Plywood	Marker pen, ruler, compass			20 min	10 min	As the inside of the compartment is now there was no need to cover the whole inside lining, instead the base of the compartment had to be covered as it's wood.
Glue the fabric onto the walls of the inside lining of the compartment	Fabric	Contact adhesive		Make sure that the fabric is glued perfectly onto the walls.	25 min	10 min	
Measure and mark out the lids for the compartments	Plywood	Pencil, compass, steel ruler			15 min		This stage wasn't carried out so that the top compartment would rotate.
PART 3: Base							
Measure and mark out the base of the compartment onto plywood.	Plywood	Pencil, compass, steel ruler			15 min	25 min	
Join the base and the bottom/side compartments together. Insert the rod into the hole in the middle of the compartment.	Plywood	Screws, drill		Ensure that the pieces line up together.	40 min	30 min	Instead of joining the compartments using screws, araldite glue was used to join them together.
Place the top compartment on top, the rod should fit tightly but the top compartment should be able to rotate.	Plywood	-			10 min	15 min	Instead of inserting a rod through the hole unit, a bolt nut was used to join the top and bottom compartment. As the rod would make it less attractive.
Spray paint and the varnish the whole unit.	Plywood	paint and wood varnish			30 min	60 min	

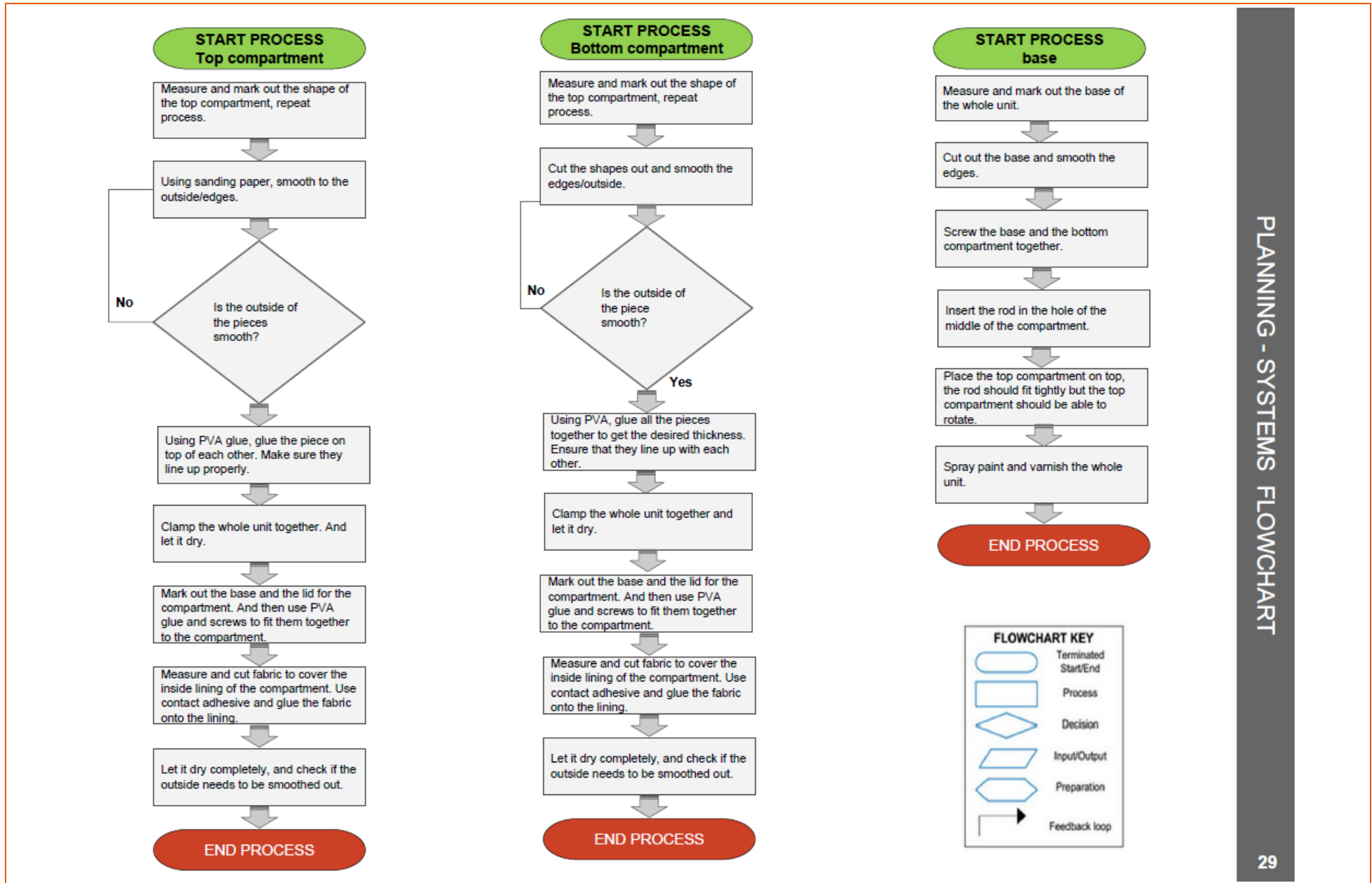

PHOTO 1



I started to mark out the shape of the compartment onto a piece of plywood using a compass.

Technical challenges: The compass would sometimes slide changing the diameter of the circle, hence I had to readjust the compass and draw the circle again.

QC check: Before drawing the other circle, I had to ensure the both centers are on a straight line

PHOTO 2



Using the piece that was marked and cut out, I used it as a template to mark out the remaining pieces needed.

Technical challenges: Even when heating on the pencil lines, the bend would sometimes fall a little short, making one face of the unit shorter than the other.

QC check: Ensure that the marking lines were thin and followed the shape smoothly

PHOTO 3



The edges of the pieces (compartments and base) were sanded off.

Technical challenges: At times I sanded off more wood than that was required to be sanded off as it was hard to sand off the edges.

QC check: Ensure that not much wood is being sanded off by stopping and checking how much wood was sanded off. Make all the sides smooth and without any edges.

PHOTO 4



Bending high impact polystyrene to make the hollow space of the compartment. The inside.

Technical challenges: The edges when put together looked unappealing

QC check: Use the jig/former previously made as the angle is still the same. Ensure that a protractor is used to increase accuracy.

PHOTO 5



I applied glue fitted in the wood and then I left the unit to dry.

Technical challenges: It was hard to fit the wood on top of the high impact polystyrene without getting glue on my hand. Sometimes a gap could be seen when the wood was fitted onto the polystyrene.

QC check: Ensure that the unit was not moved while the glue was drying and that the clamps were placed correctly.

PHOTO 6



The next stage would be use art roc or paper clay to fill in the gaps in between the compartments to make it look as if the unit was one whole piece (a moulded unit). To do that, cardboard was first glued around the compartments

Technical challenges: It was a bit hard to get the board into the gaps and gluing it.

QC check: Ensuring that the card was wrapped and secured properly. And ensuring that there were no dents.

Two pieces of plywood were cut out to fit into the space between the units in a compartment.

Technical challenges: When sanding off these two pieces, one was shorter than the other so it was a bit loose.

QC check: Ensure that the pieces were straight and aligned and not leaning to one side (since the compartment is curved) to make a space for a drawer. Ensure that when I marked them the rectangles were a little wider so that when I sand them off I wouldn't take off much wood.

PHOTO 7



The next stage is to make a box/drawer that would fit into the space

Technical challenges: Marking and drilling in the wood screws to be exact and precise. Initially the wood was marked wrongly and the pieces did not align..

QC check: Ensure that the holes are drilled accurately and the glue has dried in the correct places.

PHOTO 8



The dimensions for the empty space were measured, and a box was made so that it would act as an extra drawer.

Technical challenges: The pin was difficult to push in, and it would have damaged the bottom of the frame if the piece of plywood was not placed.

QC check: Ensure the casters are secure and put into position correctly.

PHOTO 9



Using PVA, the outside of the compartment was covered with Art Roc

Technical challenges: Concealing the niches when it was smoothed, as some areas had no surface to stick on.

QC check: Ensure that the art roc was wrapped tightly around the outside.

PHOTO 10



Using PVA glue, Art Roc was wrapped around the bottom compartment.

Technical challenges: Getting the art roc into the tight corners of the compartment.

QC check: Ensure that the art roc was wrapped tightly around the outside and that it was glued properly.

PHOTO 11



The last stage was to paint the whole unit

QC check: To ensure that all the parts were covered with paint. And that the paint masks the art roc completely.

PHOTO 12





ADDITIONAL PROTECTION: To ensure that the base of the compartment doesn't damage the surface it's going to be placed on, the base was covered in a layer of foam.

CONNECTING BRACKETS: These brackets allow the end user to arrange the units however they please, fitting their aesthetic. If wanted, they could even have one solid colour for all the hexagons, as when manufacture there would be even more options to select from.

JOINING METHODS: The methods that were used to join parts together were very effective. Araldite glue was used to join the plastic to the wood, PVA glue was used to stick the art roc, hinges were used to join the lid onto the top of the compartment. Using nails to join the sides of the drawer together, and a bolt nut to join the top and bottom compartments together. These methods were efficient and they didn't make the appearance of the whole unit change.

COLOUR SCHEME: By using the colours red, black and white, it made the overall colour of the unit be dark and not very bright. As this product is not for young kids, I planned to not make it look very colourful. The colors red and black go well together and the white contrasts the darker colours.

STRONG STRUCTURE & SUPPORT: The wide base of the unit ensures that the whole box doesn't topple over if it was to be accidentally hit. All the compartments are made using HIP and plywood, this means that the whole unit is lightweight yet has a strong structure.

ROTATING UNIT: The top compartment is secured to the base using a bolt nut and a washer, this enables the user to rotate the top compartment freely and with no problem. The compartment rotates 360 degrees.

ADDITIONAL STORAGE: The empty space between the two compartments (the top) was used as a place for a drawer. This gives the user more storage space to store other things other than jewellery.



EVALUATING AGAINST THE SPECIFICATIONS

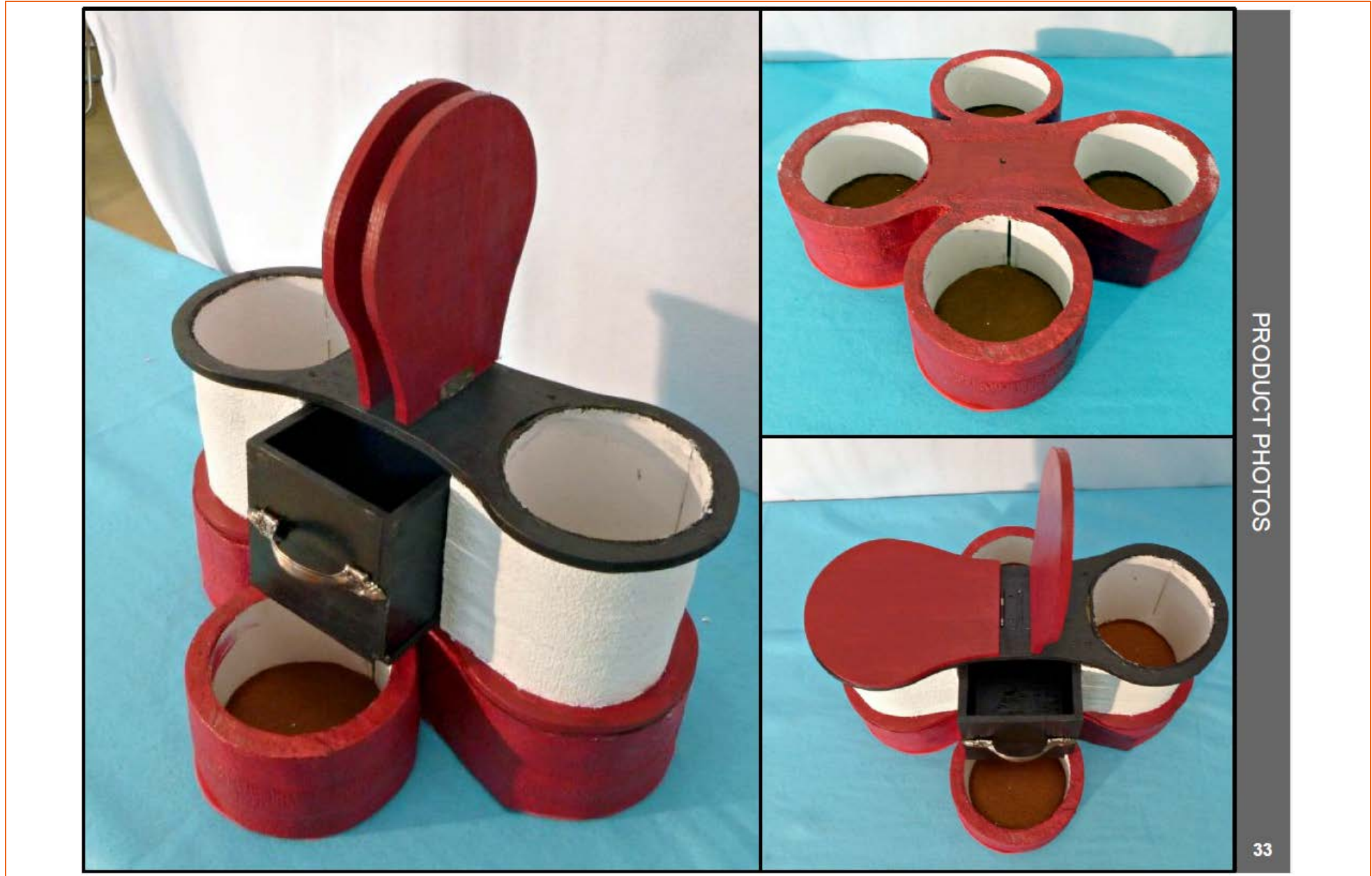

	Selected Product Specifications	Score 0-5					Specs Met? (Y/N/P)
		0	1	2	3	4	
1	To be able to store a variety of different types of jewellery						P
2	To safely store the jewellery, ensuring that their quality doesn't change.						Y
3	The user should be able to clean the box easily without facing any problems.						P
4	The size of the compartments should be big enough so that the user is able to put in their hands.						Y
5	The unit is very strong and it's made with materials that will last for a very long time.						P
6	The product looks attractive and it's shape is unique.						P
7	The colour scheme of the whole unit should allow the user to place it in different areas as it goes well with the surroundings.						P
8	The user can easily access their jewellery and put them back in.						P
9	The box shouldn't take up lots of space.						P
10	All parts should be working properly as they are supposed to						Y

CRITICAL ANALYSIS OF DESIGN PROCESS & OUTCOME

Locks can be used for the lids to secure them in place. The user will find it easier to ensure that the lids are closed properly.

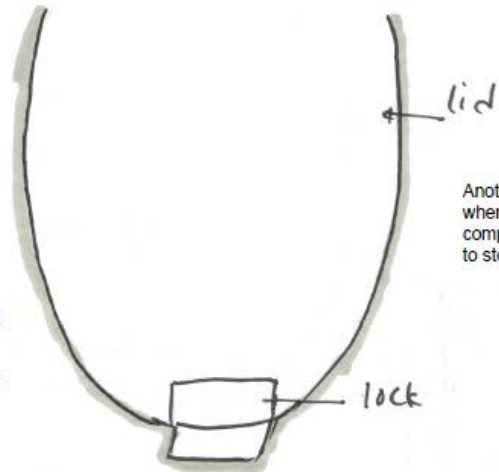

Another drawer could be added when the unit has shallower compartments. It enables the user to store extra things.

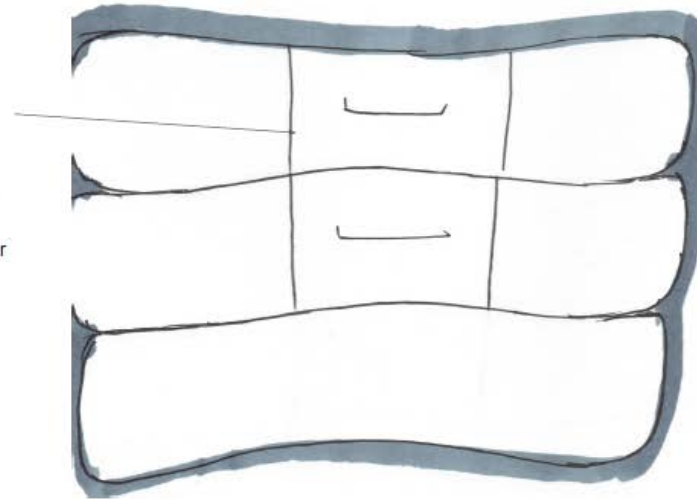

As this unit is used to store jewellery, it'll be more efficient if the top compartment was shallower than it is. Instead of having the compartment 10 cm deep, it'll be divide to have shallower compartments. This will benefit the user as they will be able to store jewellery without having most of the space empty.

This will act as a dish that can be put inside the compartments, it'll be transparent. It will make it easier for the user to access their jewellery, so instead of having to put their hands in to get what they want, all the have to do is to take the dish out of the compartment. This will be helpful if the end user has a bigger fist than the actual diameter of the compartment.

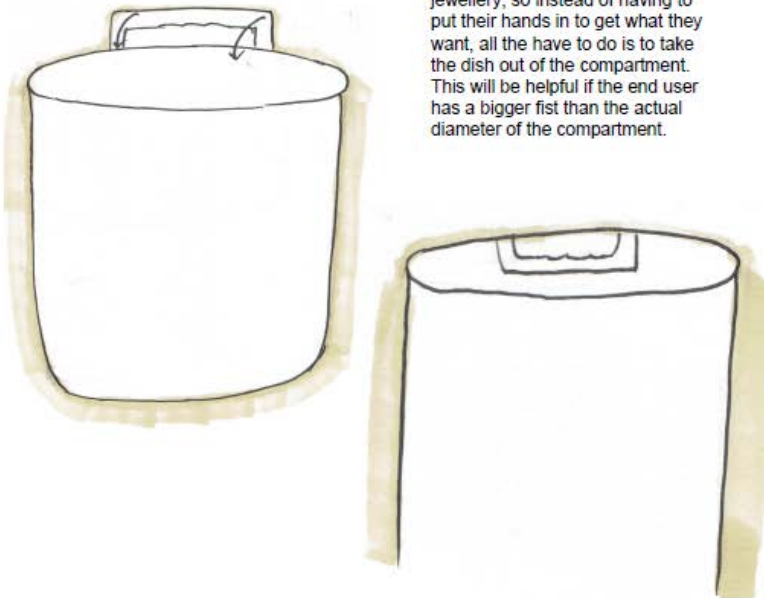

This modification will make it easier for the user to open the lids much more easily, so that it wouldn't be stuck or hard to uncover.

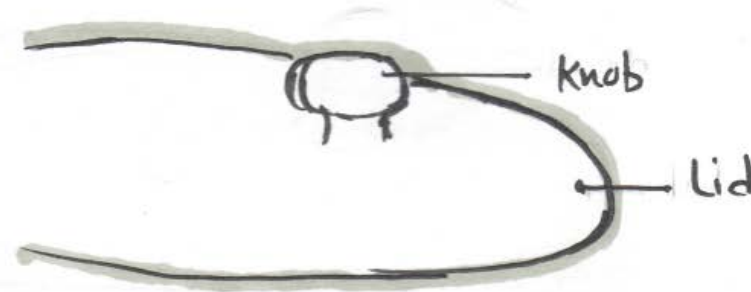

1.1 Moderator's assessment of Project A

Criterion	Comments	Mark
1. Identification of a need or opportunity with an analysis leading to a design brief	Problem analysed and need identified. Clear design brief. Limited reference to the user in this section. This is acknowledged in the marks for Criterion 2.	3 marks out of 5
2. Research into the design brief resulting in a specification	Some evaluation of existing products, outline questionnaire and possible materials and processes. No reference to range or sizes of jewellery or other important issues, e.g. security or portability. Reasonably detailed specification.	7 marks out of 10
3. Generation and exploration of ideas	A range of outline possibilities are explored with some imaginative interpretation. Some evaluation of ideas (strengths and weaknesses identified). Appropriate drawing techniques used, clear and well-presented with annotations to explore some of the technical aspects, including consideration of possible materials and constructions. Good use of CAD.	15 marks out of 20
4. Development of proposed solution	Very good development of proposed solution, with appropriate design modifications and some decision-making on materials and construction. Comprehensive evidence of modelling to inform decision-making.	13 marks out of 15
5. Planning for production	Dimensioned working drawings produced. Clear and detailed sequence of manufacture proposed.	9 marks out of 10
6. Product realisation	Completed to a high standard, fulfils the requirements of product specification and functions well. Excellent photographic record of manufacture.	26 marks out of 30
7. Testing and evaluation	No evidence of testing with jewellery items added or the box being used. Outline evaluation against specification identifying some strengths and weaknesses, no supporting justification or comment. Some improvements identified.	6 marks out of 10
Total mark awarded		79 marks out of 100

Section 2: Project B – Environmentally-friendly egg carton

Brief

I will design and make a reusable and more environmentally-friendly egg carton which will be able to hold approximately 1 kilogram of eggs per egg carton for supermarkets in Indonesia which sells eggs per kilogram. This is to help buyers to transport eggs safely to their destination. Buyers would be able to take home their eggs home conveniently and absolutely safe instead of using the cheap plastic bag that supermarkets usually provide as the eggs are more prone to collide with other eggs or other objects. This improved egg carton will allow supermarkets to provide an alternative solution for carrying eggs which is better than the current one and would help decrease the waste of plastic bags as the egg cartons would replace the plastic bag and be reusable every time a consumer would like to purchase eggs from the local supermarket. Everyone who buys eggs should be able to use the egg carton and it would be an improvement for the of buying eggs per kilogram as it ensures egg safety on the journey and improves the well being of the environment. This product would be able to be produced easily in factories and quickly mass produced.

Situation

Every time my mother goes shopping, she has to be really careful when carrying eggs for daily consumption. She usually purchases them in supermarkets where all the eggs are put into one plastic bag because the supermarket does not provide any egg carton. Unlike in egg cartons where the egg won't move around, the plastic bag doesn't ensure for it not to crack on the way home so after getting them from the supermarket, my mother has to pay more attention to the eggs; she has to make sure the eggs do not crack when taken home.

The journey involves walking from the market to the car and from there she drives home using a car. Walking from the supermarket to the car involves carrying the eggs gently and has to always be held to prevent it from hitting other objects or each other and if the road is uneven or if she has to drive fast, it causes the eggs to hit against each other as well. This problem is because of the lack of any appropriate packaging to help egg buyers ensure the safety of the egg when traveling home with their eggs as the supermarket would want to decrease the budget so they would not have to spend excessive money on packaging of products

I am sure that this case happens to many other people as lots of people buy eggs the same way as my mother does. By making a product that is cheaper than the current egg carton provided in the supermarkets which also help keep eggs safe for transport, this can help many people a lot.

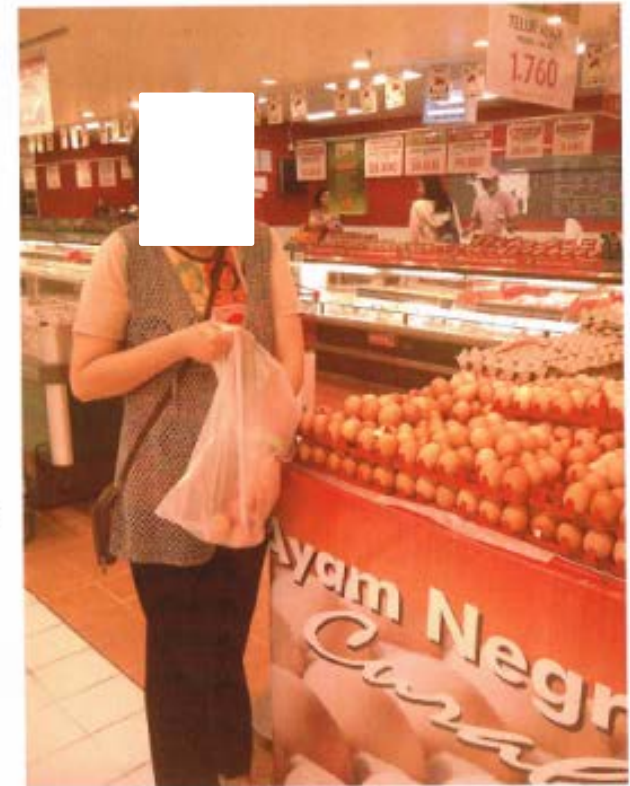

Research

To gather the necessary information regarding making the ideal egg carton, to see the most preferable type and style of packaging, I interviewed some people who were buying eggs in the nearest supermarket which sells eggs both per kilogram and sold in plastic egg packaging.



1. Why buy eggs per kilogram?
2. Do you have problems when taking eggs home?
3. Do you give extra care for the eggs than other products when taking them home?
4. What would be an appropriate packaging?
5. Do you think plastic bags are good packaging for eggs?
6. Describe an ideal packaging
7. What vehicle do you use to get home?
8. If the supermarket provided a packaging that is reusable, would you use it over and over again or just once?
9. Would you rather buy eggs with the packaging or buy a separate packaging?

Research

Any problem in taking

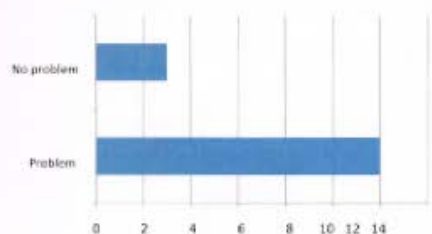

One out of the five customers interviewed says that they don't have problem in taking home the eggs while the rest of the people asked says that they have problem with their eggs

Consumers says that an ideal egg carton is made of polyethylene as it can be used over and over again. An ideal packaging would be strong and has a handle for easy carrying. It should be hard and lightweight. Consumers would use the packaging over and over again although it also depends on how cheap it is and how safe for food the product is.

Egg Carton Material

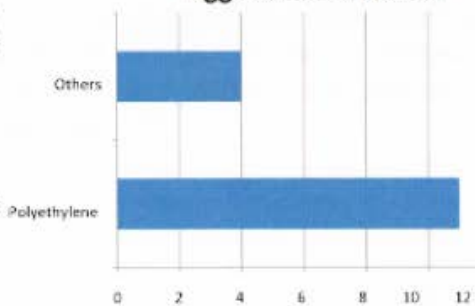

Eggs per kilo or in packaging

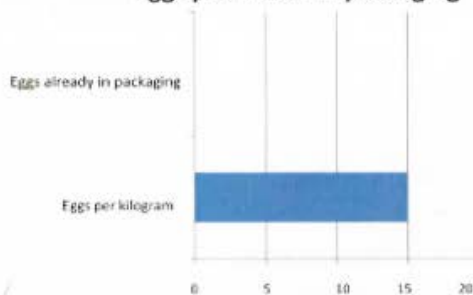

All of the consumers surveyed says that the eggs are cheaper when bought per kilogram and some with an addition that it is better in quality and can be handpicked so the condition of the egg would be good.

Vehicle Used

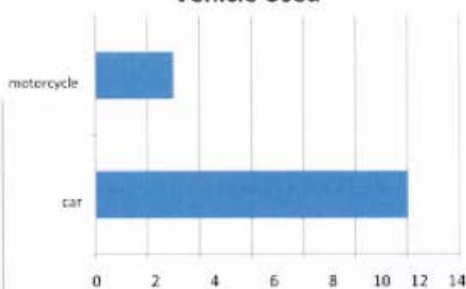

Four out of five people use cars to get home while others use motorcycle to get home.

How eggs are presented to customers in the supermarket

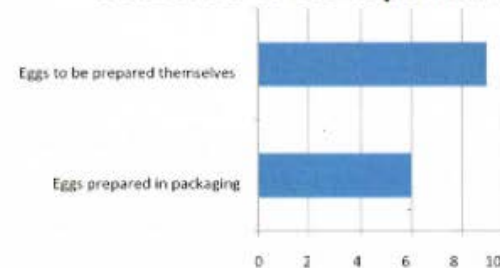

Two out of five people wants the eggs already with packaging while the rest feels it depends on the price and the quality of the packaging itself

Plastic bag ideal as packaging or not

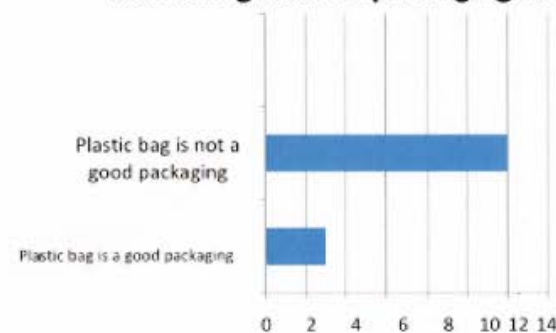

One out of five people also says that the plastic is good enough as it still is able to contain eggs and transport them. Others wishes packaging that can keep eggs safe from getting cracked or broken.

Research

Any extra care given when taking eggs home

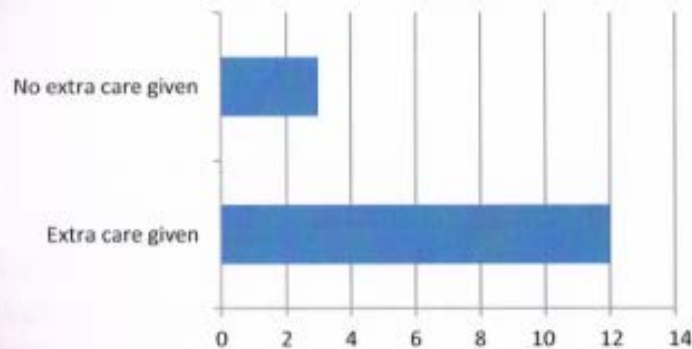

One out of five people asked whether extra care was given says no, saying that they treat eggs the same as other products unlike the other four out of five people which says that special care was given to the eggs.

My conclusion is that I need to design an egg carton which is strong and sturdy so that the eggs don't get broken easily and thus the eggs can be treated as if it was any other product.

Many of the people surveyed likes polyethylene egg carton but since I want to design an environmentally-friendly egg carton, I will be considering slightly different material which is lightweight yet strong.

My design should fit for cars more than it should for motorcycles since more people surveyed uses car than motorcycles. The design I will make should be cheap but sustainable and durable to be used over and over again.

Research On Eggs

To make an ideal egg packaging. The sizes of the eggs must be documented. After buying 10 randomly chosen eggs in the supermarket, as if it were real case scenario, I documented the egg sizes by squeezing the eggs between two blocks to document the width and height of the eggs accurately.

From the data gathered from the table, I conclude that the holes the egg sit in should be about 4.5 cm as it is the average width of the eggs. From this data the egg carton must be over 6 cm as the largest egg size sold is at 6 cm. The egg carton must be longer than 6 cm to prevent the egg from getting direct impact from the pressure exerted from the egg container to the egg directly. If there is a gap between the egg and sides of the egg carton, it would minimize the damages or won't damage the egg at all.

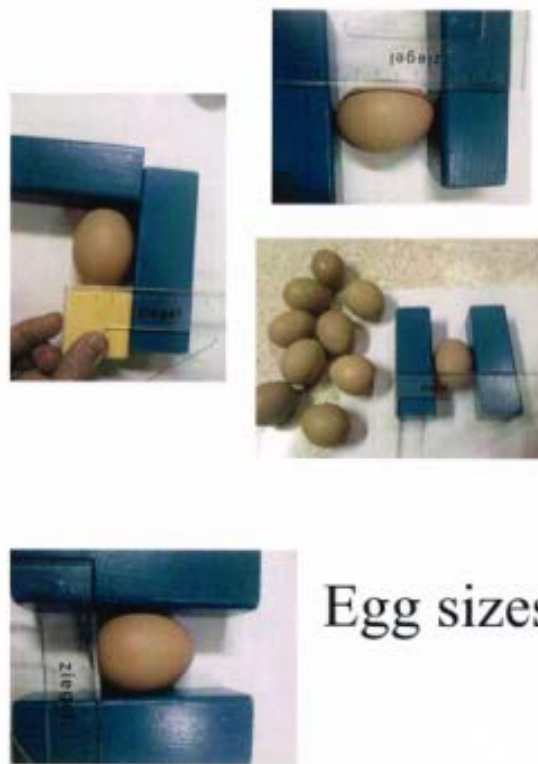

Egg	Width	Height
1	4.5	5.9
2	4.5	5.7
3	4.6	5.9
4	4.5	5.9
5	4.5	5.8
6	4.4	5.7
7	4.6	6.0
8	4.5	6.0
9	4.4	5.8
10	4.5	5.9

*Data in cm

Egg sizes

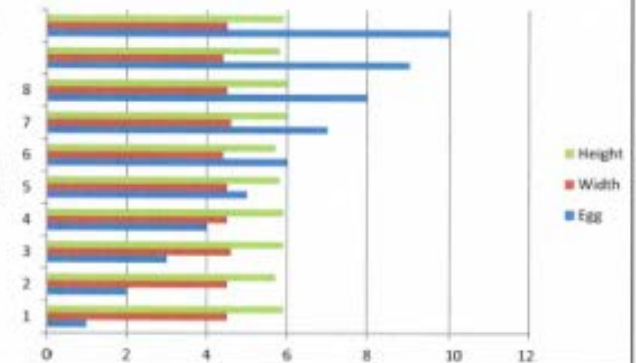

Egg Strength

(ISNS) -- Breaking an egg is a lot easier along its side than at its tip, and scientists can now say exactly why -- and by how much.

This new information could help bioengineers better understand the biological structure of egg-shaped cells -- and how those cells might respond to medications.

Two different research teams independently developed a way to derive how strong an egg-like object is based on its shape and what it's made of.

Egg-shaped objects, or ovoids, are common throughout nature, and can be seen in chicken eggs, the organelles of cells and the outer shells of some viruses. Up to now, finding the rigidity of any size of egg-shaped shell had to either be approximated with estimates based on the properties of spheres and cylinders, or measured directly using specialized lab equipment.

It's well known that the strongest part of an ovoid is at its narrow tip. The sharper the curve of an ovoid, the stronger and more rigid it is at its tip.

"What's new is that we kind of tried to study a class of shapes," said Dominic Vella, a mathematician at the University of Oxford, in the U.K., and lead author of one of the papers.

In the past, researchers studying the structural properties of ovoids had to approximate their calculations using equations for other shapes for simplicity's sake.

Massachusetts Institute of Technology engineer Arnaud Lazarus, and lead author of the second paper, said that the two teams' work could be used to infer the properties of an ovoid without breaking it open.

"Our formula is that if you apply a force on that shell, and it deforms, you can predict how thick the shell is," said Lazarus.

Conversely, a researcher can deduce the cell's internal pressure by knowing the thickness and material properties of a cell's outer casing. This is important when developing new treatments because if a cell is under a lot of internal pressure, it might be harder for a new medicine to seep inside, but could be more prone to bursting.

"The field of cellular mechanics is always searching for theoretical models through which to extract material parameters from experiments," said K.C. Huang, a bioengineer at Stanford University who did not work on the research. "Beyond important fundamental questions of biological material properties, these studies may also find applications in the design of thin shell geometries with specific mechanical behaviors such as differential rigidity and buckling."

From this passage on the left. I can conclude that I need to make emphasis on the sides of the egg when designing the egg carton as they are weaker than the tip of the egg. This is to ensure the chances of the egg breaking is lower.

Specification

Function:

- Product will hold eggs
- Product will protect eggs
- Product will store eggs
- Product will transport eggs

Cost:

- Product will cost lesser than current egg cartons

User:

- Product should be used by everyone who purchases eggs when buying them per kilogram
- Product must be able to be used by drivers or car passenger or motorcyclist

Environment:

- Product must be environmentally friendly or recyclable

Ergonomics:

- Product must be mobile and easy to carry

Deadline:

- Product must be done by the 17th of April

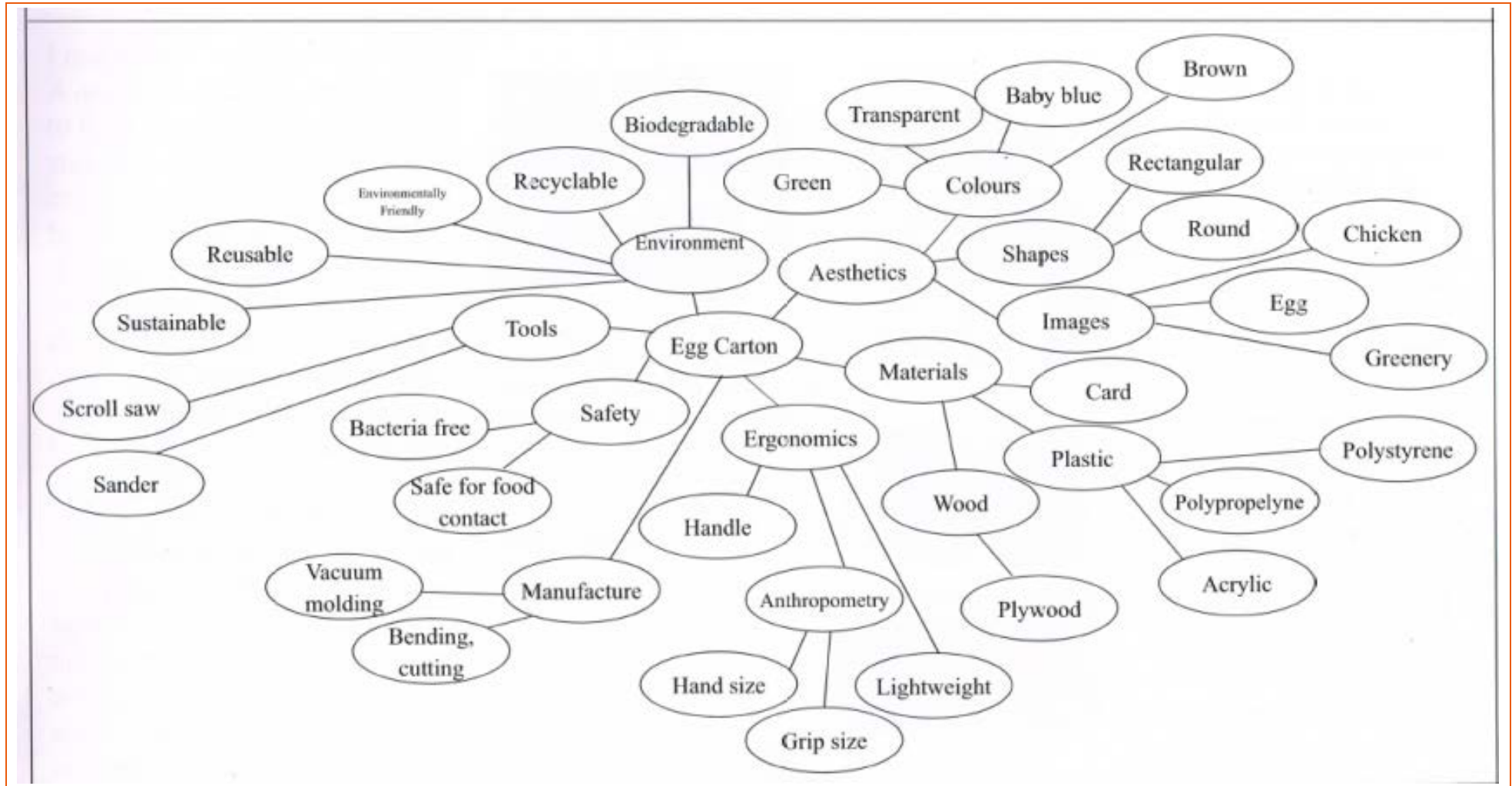

Net of design

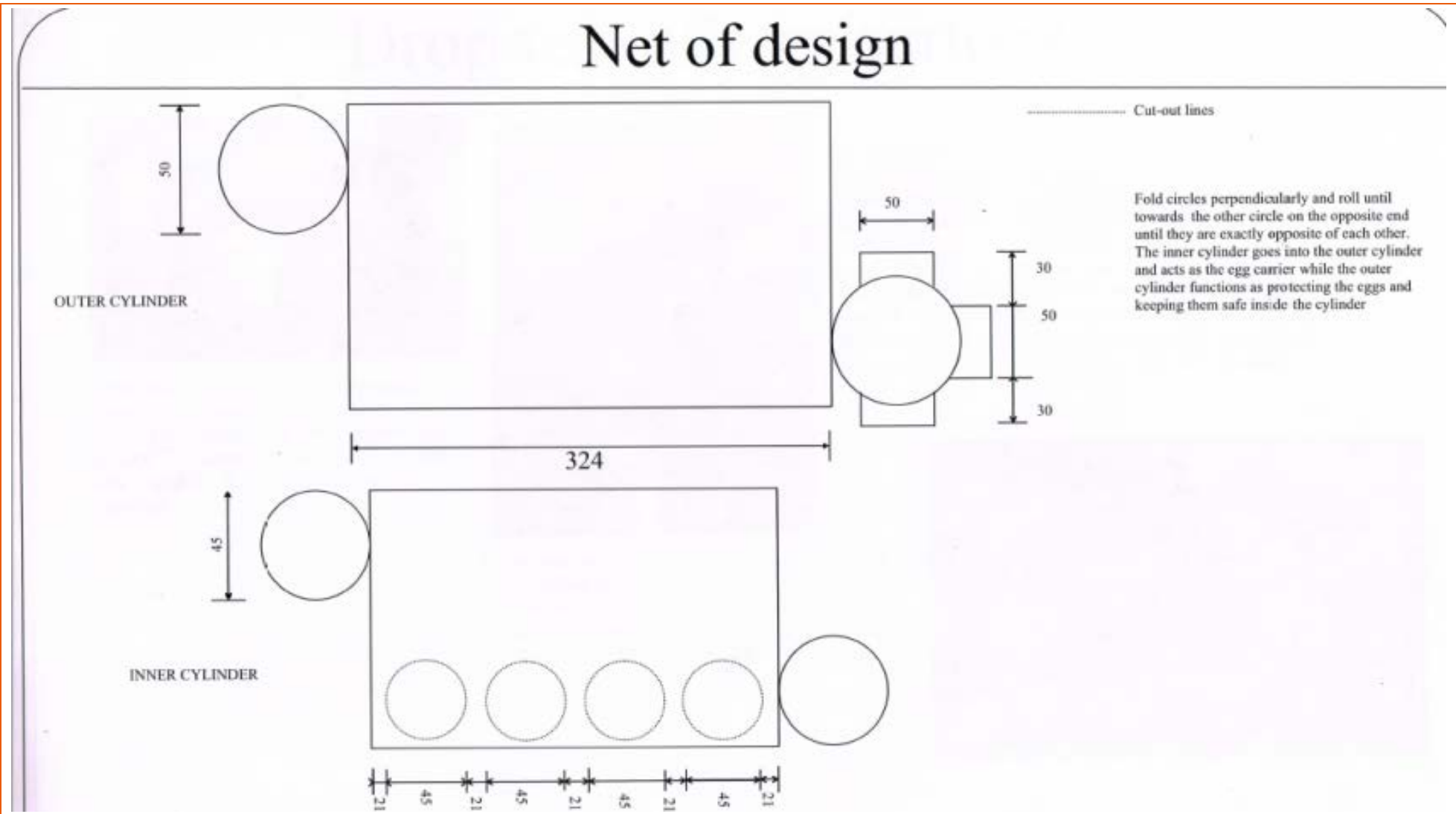

Product Analysis

I researched different egg cartons. A quality egg carton must be able to hold eggs, keep them safe and still keep the eggs possible for consumption. The egg carton must be the right size so that it is not difficult to carry but still hold enough eggs so that it is not difficult as carrying lots of egg carton with little amount of eggs is just as difficult when carrying a heavy large sized egg carton with lots of egg in it. In the end the egg carton would not be able to serve its function as an egg carrier and egg protector. The egg carton must be easy to carry otherwise it would not be comfortable to carry eggs around. The egg carton should make it comfortable to carry eggs



This product is quite sustainable and sturdy, able to keep eggs safe. It is made with recycled plastic safe for food, meaning environmentally friendly and not hazardous. It is easy to wash as it is dishwasher safe.



This product is eye catching and can be recycled easily because it is made of paper. It can hold 12 eggs and looks quite sturdy as it has pockets to keep eggs from moving around and keep eggs from getting crushed



Protect eggs from getting broken. Product looks sturdy and strong. It has a handle to make it easy for carrying. The colours are eye catching, with bright colours. The holes in the product should be able to allow egg to stay in place when being carried around.

Initial Ideas

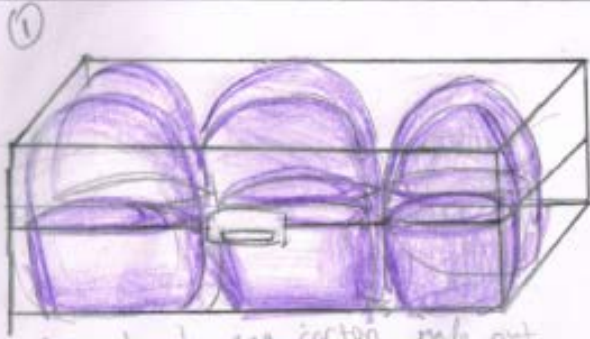

See through egg carton made out of polystyrene. This design is similar to the standard egg carton. It should be able to store up to six eggs and is quite mobile. There are built-in egg sized holes which are concave to hold eggs in place securely.

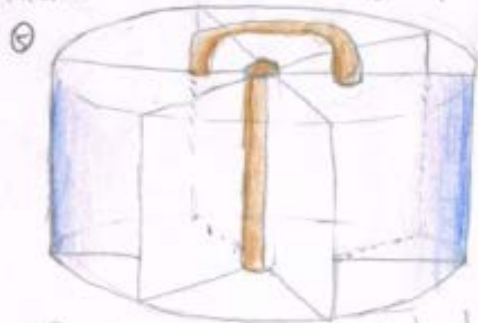

Circular egg carton which holds eggs in place. Top and bottom have foam to prevent top and bottom part from cracking. Product seems to be quite lightweight.

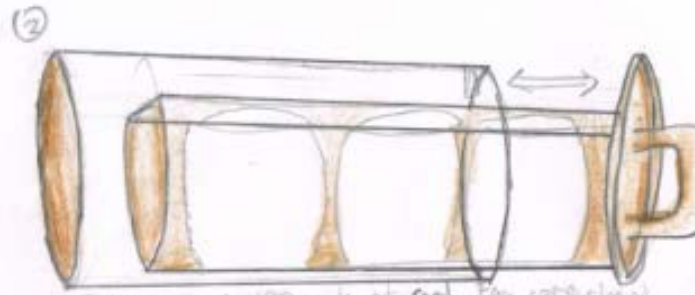

Tube egg carton made of cardboard. Egg compartment can be pulled out for easy storage.

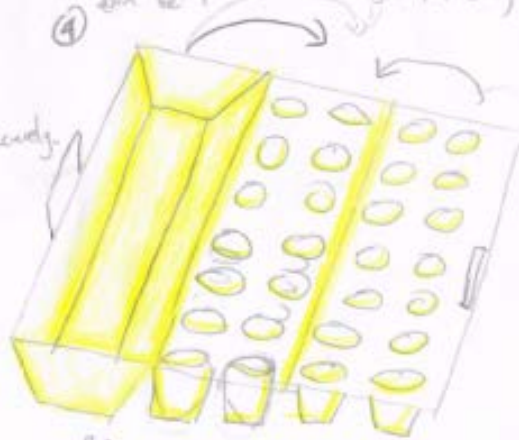

Polystyrene egg carton which folds to keep eggs secure and prevent the eggs from getting broken.

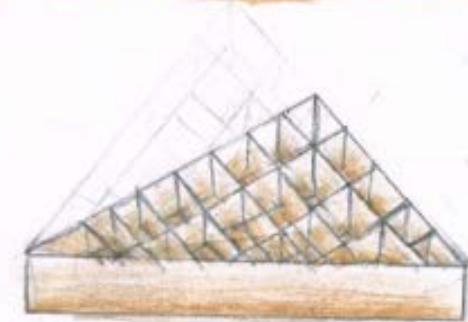

Triangular cardboard box with lid that can hold many eggs and still keeps eggs safe. Card would be sturdy with triangular structure. Box can be put in shopping cart and in car trunk. Eggs will sit securely in place.

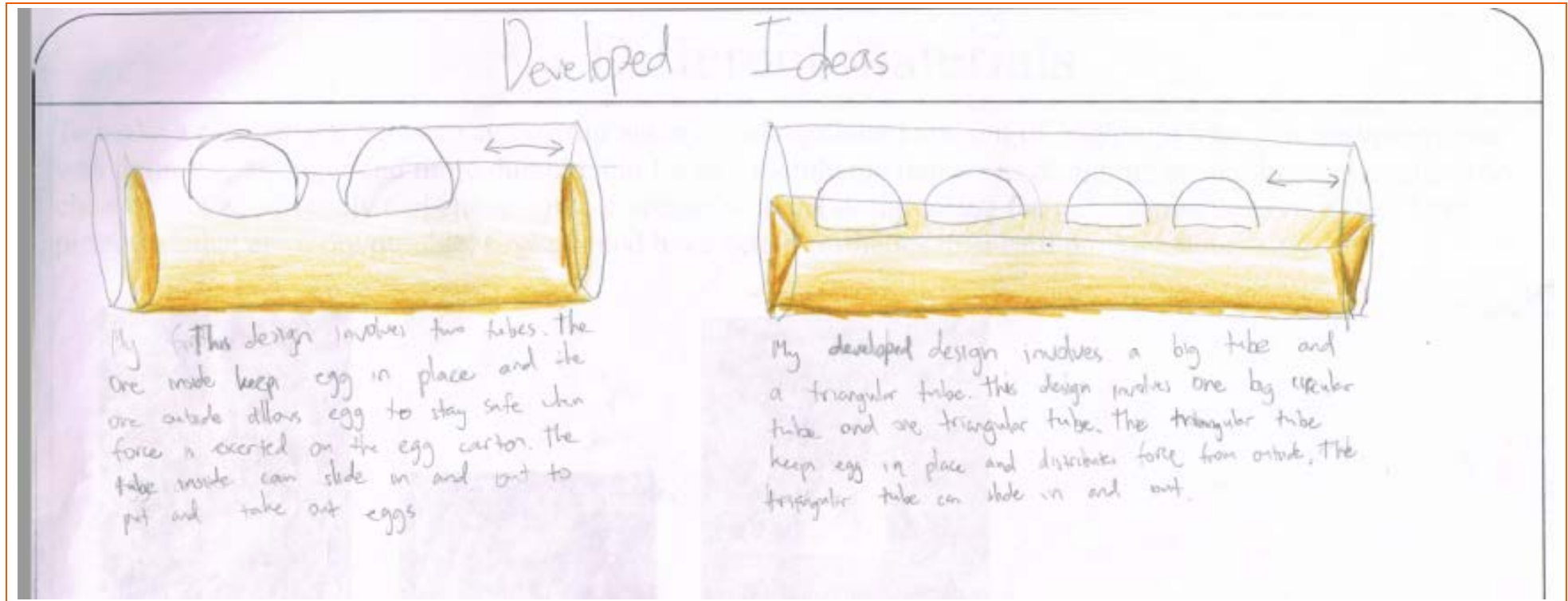

Different materials

To make a comparison between egg carton made out of cardboard and out of polypropylene. The polypropylene was definitely stronger and more durable, but I was remembered that I was designing something that ought to be cheaper and eco-friendly and chose not to continue with the design using the polypropylene even if they have properties that are more durable, stronger and have better aesthetics than card brown colour.



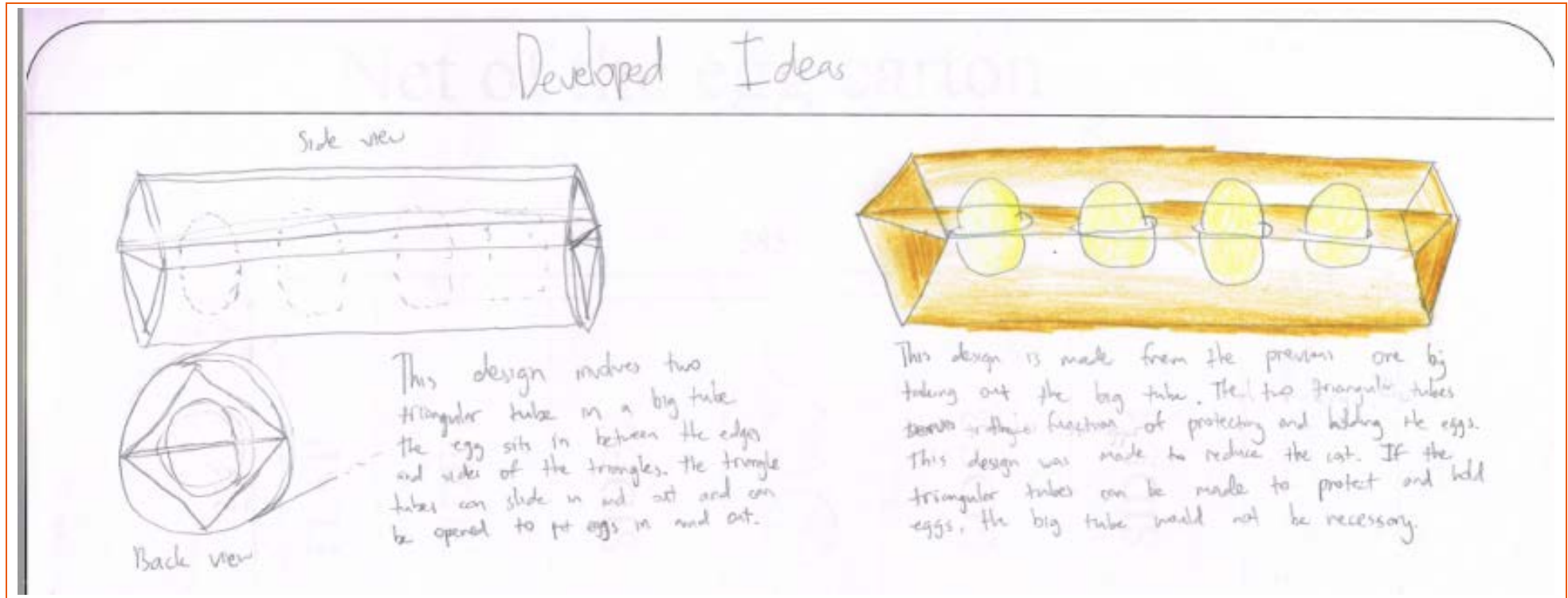

Net of the egg carton

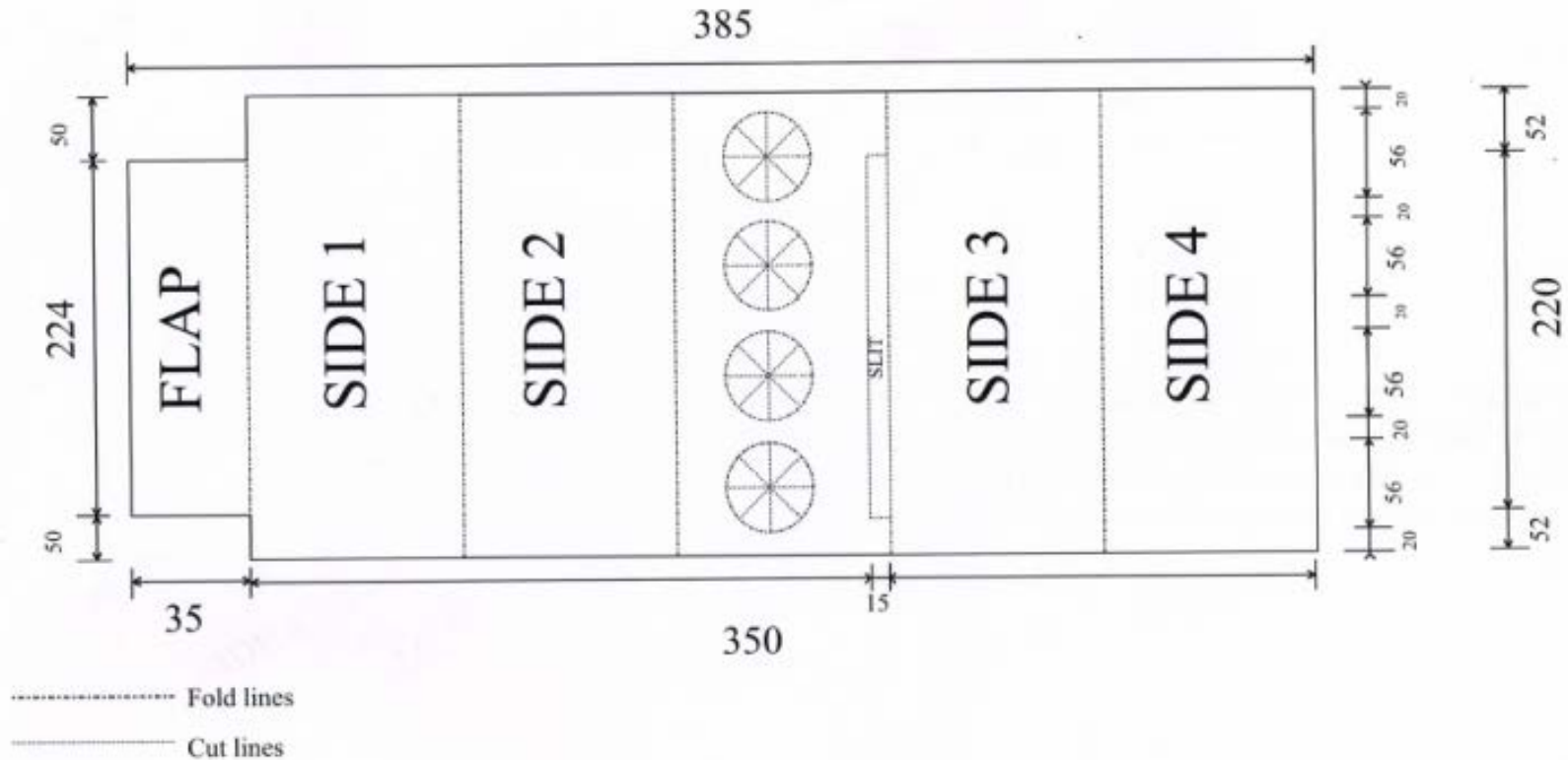

Folding in the Net

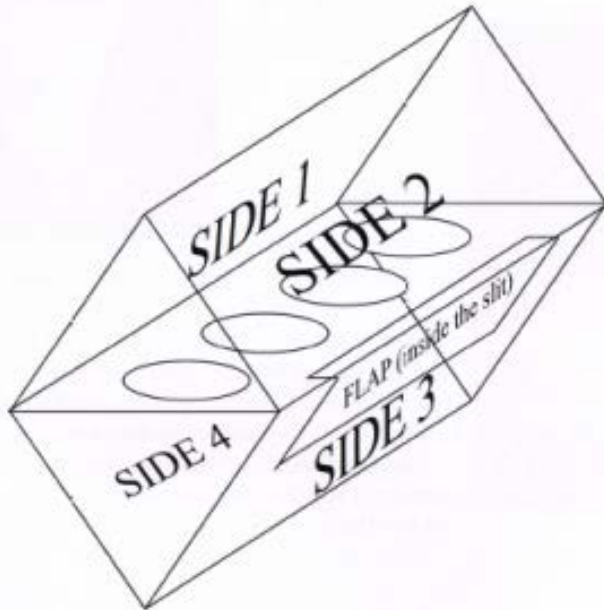
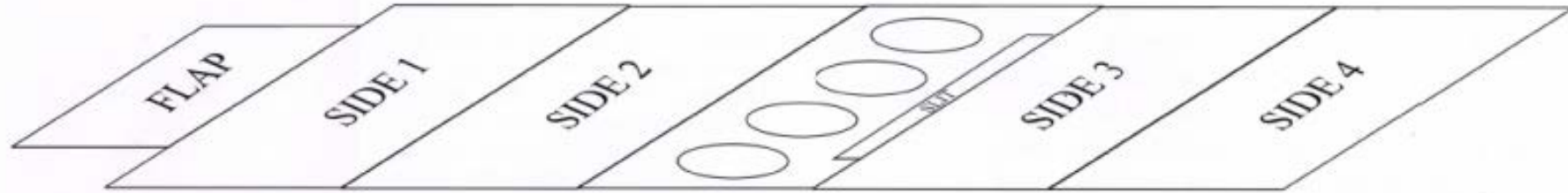

Fold SIDE 1 and SIDE 2 over the egg holes and insert flap into the slit which have been cut out. Fold SIDE 3 and SIDE 4 under the egg holes and glue them in place with the glue gun onto the opposite edge of the slit.

Egg Carton Drop Test



I cut the triangular tube in half and made the triangles into a diamond shape. The egg sit inside, between the two triangles. This then goes into the big tube and was dropped. There was a small crack. After a few times, the egg carton ripped. This shape is already good enough to withstand impacts. The improvements needed is thicker and stronger card and new design for the holes.

Using the corrugated cardboard, the egg carton is developed into two triangle tubes. The egg sit in the middle. My hypothesis was that it may not be necessarily due to sharp edges but due to the thin cardboard that the egg breaks, but after dropping the egg with this egg carton, the sides of the egg where it touches the edges of the cardboard still broke. I conclude that the sharp edges contribute to the breaking of the eggs. There was also a new problem with this egg carton. The flaps to keep eggs encased will fall out by itself due to the weight of the eggs and also as the egg carton is used regularly, the holes for the flaps will keep getting bigger and slowly rips. This may be a problem as the eggs will fall out.



I developed the design to have instead of one long flap, I used two smaller flaps. Its is a better way of keeping the eggs inside although it is a little bit harder to slide in. Instead of regular holes, I slit cardboard in a series of diagonal and horizontal-vertical slits to form a cup for eggs. I designed it in two ways to fit the egg, putting the egg in rectangular holes or circular holes. After testing it the oval shape is better as the rectangular shape allows the egg to slip and fall more easily than the oval hole.

Locking Mechanism and Hinging

In hinging, I slightly cut the corrugated cardboard until it cuts halfway through the cardboard using a cutter to make it fold accurately and tidily.

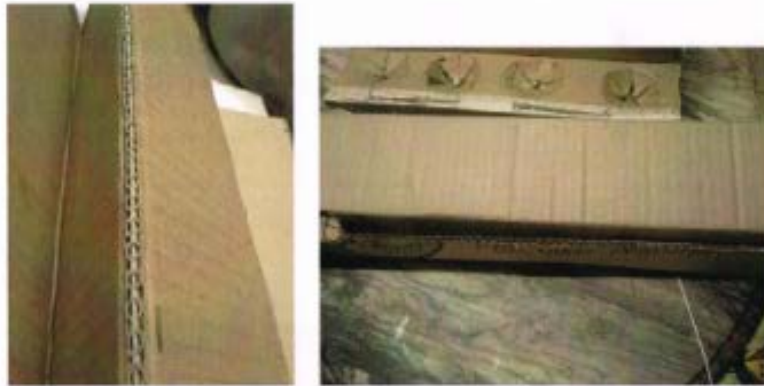

The locking mechanism uses flaps and slits. At first I designed the flap to hold in the cover of the egg carton to just be one long piece of cardboard. The result of this causes the cover to slip off easily over time. Afterwards, I designed the egg carton to have multiple flaps which results better as it can keep the cover in place even after the egg carton was dropped. The example of the multiple flaps is in the picture below.



How Egg Sits In Place

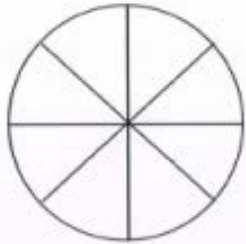

The cross sections are cut using a cutter and then it is folded downwards to form a cup like shape for the eggs to sit in

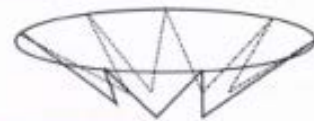

In other designs there are cups the size of eggs which allows the eggs to sit in place. My first designs involves a hole, just slightly smaller than the egg to allow the egg to sit in the middle of the egg carton, floating just above the bottom and a few centimeters from the top. After testing this design, I found it to be not very effective as the sides of the holes create pressure large enough to crack the eggs when force is applied. Therefore, a different approach in the way the egg sit must be made, so I designed a way to hold eggs safely and creates less pressure by eliminating the small area on the sides of the holes, replacing it as a series of horizontal-vertical and diagonal cross sections, where cuts that run through the middle to form six equal sectors in the circle. This design also allows different sizes of eggs to be able to be put without falling loosely or being too small for the hole as the carton can bend in and out according to shape.

Final Design

After remaking the egg cartons, I sewed them together at the lower half at the edges of the carton.



I intentionally made it loose so that the cartons can be pulled together to form this star shape. This is for easier carrying as this way someone can hold it just using one hand, sling it around the arm when they are on their motorcycle or if they have a hanger in the car they can keep it there and it would still stay safe. The eggs would sit in the middle of each parallelogram and will not get damage from any impacts. This is an easy way to carry eggs as you can put the eggs in the holes, close the lid and roll them up. When you have reached your destination you can roll it out and put the eggs in the refrigerator. The triangular shaped exterior keeps eggs safe as triangles can handle high pressure and ensures the safety of the egg. In the car or in when carrying even if the egg carton is bumped against other objects it will stay safe.

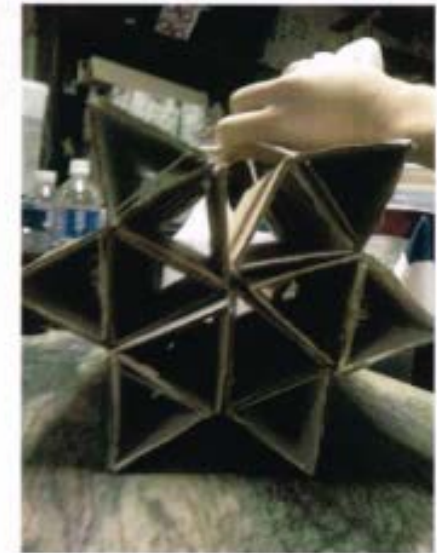
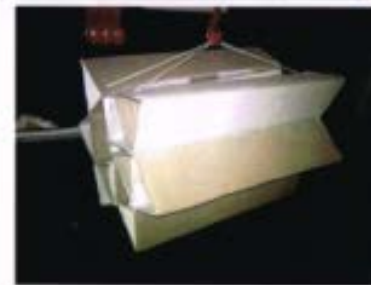

Stitching the egg carton

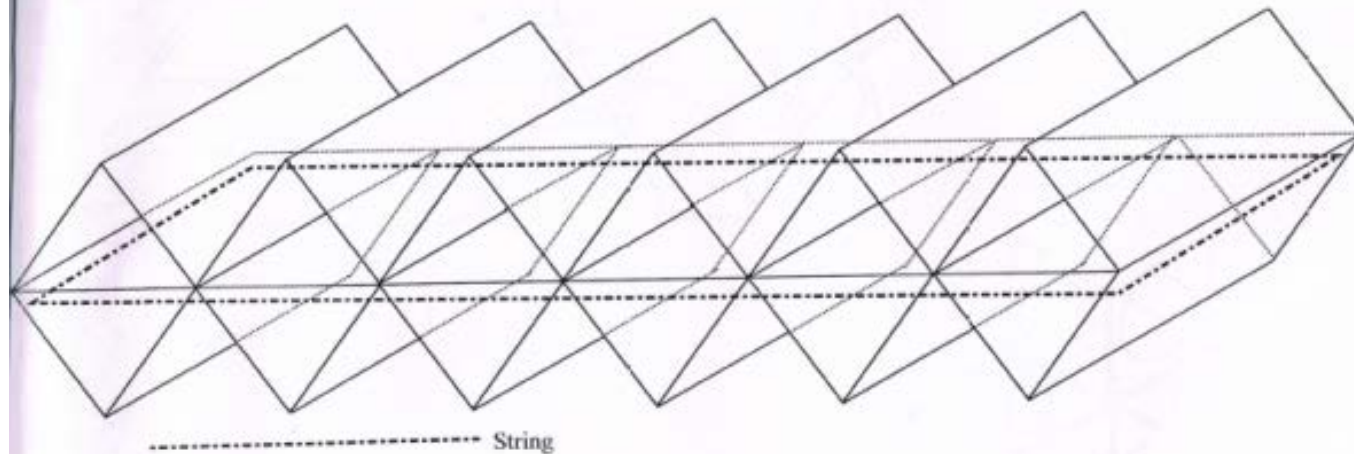

String is stitched from one row to another like in the pictures, in a perimeter, 1 cm from the edges. The string is tied loosely so that the string on the sides can be pulled to create a retractable handle. The diagram on the left shows the the perimeter of string which goes through the egg carton.

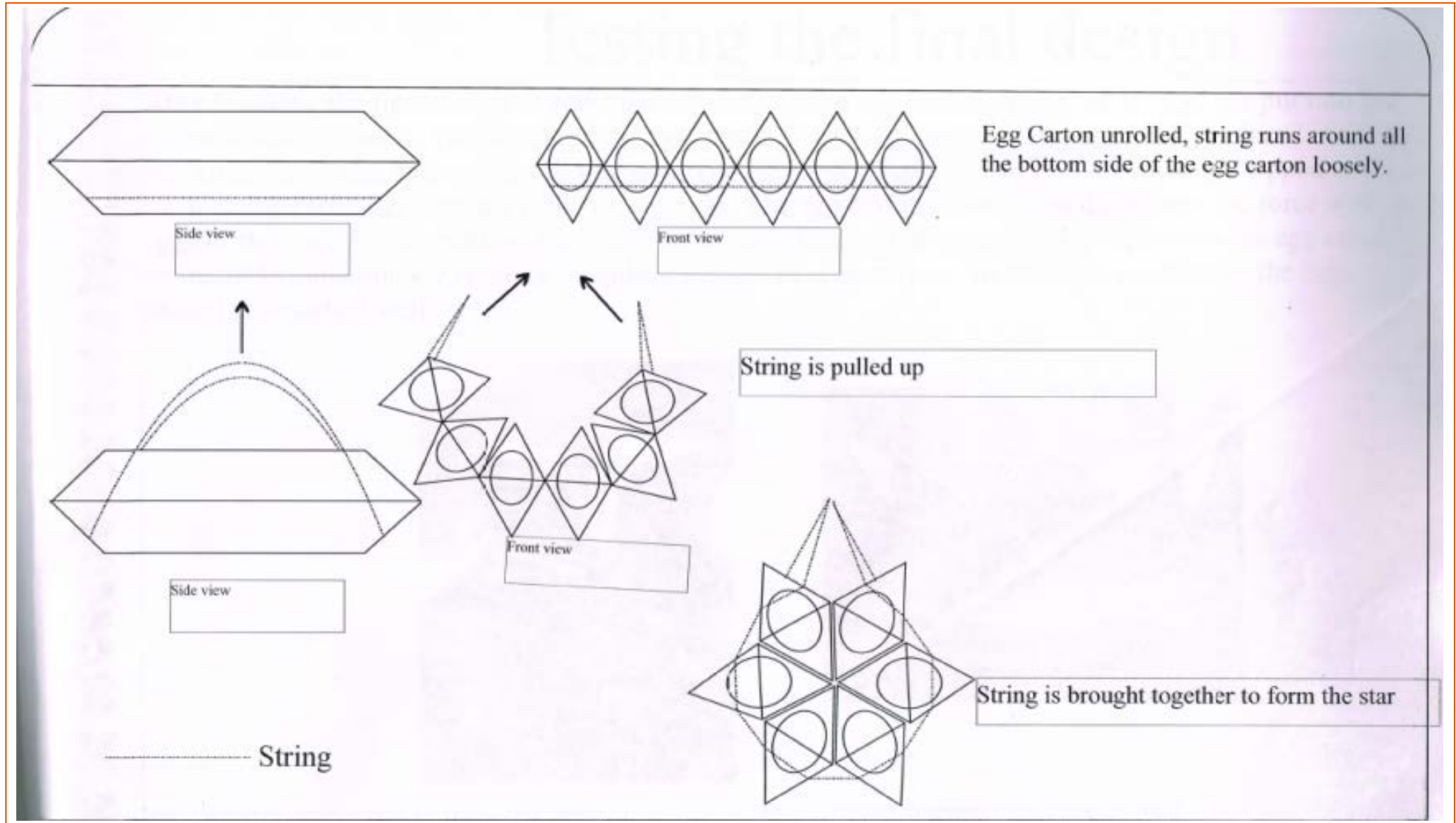

Testing the final design

After finishing the final design. A few tests are done on the egg carton. A total of 24 eggs are put into the egg carton to test the result. The weight of the egg carton is over 1 kilogram. Less eggs can be placed inside to hold just one kilogram of egg and would still function. The egg carton functions well as after being dropped to the ground while being carried to simulate if the rope breaks. The egg carton absorbs and distributes the force well, allowing eggs to stay safe from breaking. Test are done when rolling out the eggs harshly and when the egg carton is placed on the table quite quickly creating an impact against the egg carton. No damages are done to the eggs since the impact is absorbed well.



Testing in the supermarket

After finishing the final design of the egg carton, I gave my mother the egg carton to test it herself. After trying I asked her what she liked about it and what are the improvements needed. She said that it was exciting to use and it did not seem as hard as she thought. It was quite simple to use and easier to use other than the conventional egg carton. The only set backs to the egg carton is that she is limited to buying 24 eggs at a time so it would be harder for her to buy more eggs as she has to use more egg cartons. But since it is not very often she buys over one kilogram of eggs it is still good enough. The second problem is that she found was that cardboard did not seem to be a very long lasting material as overtime it would weaken but since my brief was to make it cheaper and environmentally friendly, cardboard was the best choice to make it out of. She said if I was designing for a long lasting and more durable egg carton I could try to use the polypropylene but since it is a different brief the egg carton works really well.



Evaluation

Evaluation based on specification	Score
Function	
Product will hold eggs	4
Product will protect eggs	4
Product will store eggs	5
Product will transport eggs	5
Cost	
Product will cost lesser than current egg carton	5
User	
Product should be used by everyone who purchases eggs when buying them per kilogram	3
Product must be able to be used by drivers or car passengers or motorcyclist	4
Environment	
Product must be environmentally friendly or recyclable	5
Ergonomics	
Product must be mobile and easy to carry	4
Deadline	
Product must be done by the 17th of April	5

*Score out of 5

Improvements

I think what can improve the egg carton is that it should be more aesthetically appealing to attract more customer to use it. The egg carton must also be more durable by using a different materials which is as environmentally friendly as the egg carton but stronger and more durable than the egg carton. The egg carton must also be designed to suit motorcyclist better as it is still quite difficult for the motorcyclist to use it.

Evaluation Based On Specification

The egg cartons able to hold the eggs well but as the egg carton is used more often, the holes for the eggs will get bigger and it would be loose when smaller sized eggs are put inside. This increases the chance of it breaking as when there is force applied, the egg will move in its place and collide with its surrounding, increasing the chance of it breaking.

The product is able to protect eggs very well but if very large force is applied on it the strength of the cardboard would be overcome and it might break such as when it is crushed by heavy objects or falling from a tall place.

The product stores egg excellently as 24 eggs are able to be put into a small space and comparing to the regular egg carton, it stores eggs and protects it better than those polyethylene egg cartons.

The egg carton transports egg very well as 24 eggs can be transported easily as it can be carried like a handbag.

Product costs lesser than current egg carton. The egg carton was made using cardboard and string, which is cheaper than polyethylene plastic. In the supermarket, the egg carton would greatly reduce the cost of the eggs in egg containers when using the egg carton which would attract more customers because the price is cheaper.

Some people might find the egg carton is not worth a try as some people want to buy more than 24 eggs or might not find the egg carton appealing enough to try as they are already comfortable with the regular polyethylene egg carton.

Product can be easily used by car drivers or passengers as the egg carton can be hung on hooks that are usually installed in the car, put on the seat or hung around the neck of the seat. In motorcycles, there are usually hooks near the feet of the motorcyclist or the egg carton can be slung onto the shoulders of the motorcyclist. It is still quite difficult to arrange the position of the egg carton when using motorcycle since the egg carton is quite big and it might get in the way of driving the motorcycle.

Product is environmentally friendly as no plastic is used. The string and cardboard is biodegradable. Not only is it made out of environmentally friendly materials the cardboard is reused from old boxes. When product is used in the supermarket, it can be easily made using the unused cardboard that were used to carry products from factories to the supermarket. This will allow less cardboard to be wasted.

Product is easy to carry especially for just 24 kilogram of eggs you can carry it easily with one hand. It is quite light as cardboard does not weigh a lot.

2.1 Moderator's assessment of Project B

Criterion	Comments	Mark
1. Identification of a need or opportunity with an analysis leading to a design brief	Comprehensive investigation and analysis of design need with some detail of user. Clear design brief.	4 marks out of 5
2. Research into the design brief resulting in a specification	Primary research with links to supermarket. Questionnaire provides useful information, specific details / sizes of eggs and packaging. Some analysis of existing cartons. Limited specification.	7 marks out of 10
3. Generation and exploration of ideas	A limited range of solutions. Some ideas are clarified with reference to the specification. Appropriate drawing techniques with limited annotations to explore some aspects of each idea. Some originality and development detail included.	10 marks out of 20
4. Development of proposed solution	Comprehensive evidence of modelling and trialling to assist decisions about form and materials. Very good, relevant, iterative trialling and testing of models with drop tests. Consideration of development net options and securing methods. Good use of appropriate drawing methods which assist the clarification of the technical specification of the item to be manufactured.	14 marks out of 15
5. Planning for production	Dimensioned working drawings with method of securing innovative package. No evidence of planning.	5 marks out of 10
6. Product realisation	Well-made, functional product meeting most requirements of the specification. Innovative proposal.	20 marks out of 30
7. Testing and evaluation	Objective testing and evaluation carried out in the environment for which the product was intended. Product evaluated against specification and by customers. Identification of strengths and weaknesses of the product leading to some conclusions with proposals for further development.	9 marks out of 10
Total mark awarded		69 marks out of 100

Section 3: Project C – Auto-tempered fan



DESIGN BRIEF

Design need:

Sometimes I have a lot of work to do in my laptop and when it's hot, it's sometimes discomforting and it distracts me from working. That mainly happens when I don't have the access of air con or a big fan. I also need that when the temperature decreases it stops spinning.

Design brief:

What I am going to make it's a fan that turns on automatically when the temperature rises to 27°C. This is because at this point is when the heat and room temperature start uncomfortable for the user. The fan plan was apart from being temperature dependent was to be accessible, at a low price and portable so the user can take it wherever he/she wants to. It has to be low price as it will be designed for people who don't have enough money for a big fan so this is a cheap and easy practical solution.

Intended Users:

The intended users are people that tend to work much on a laptop, like students and really anyone which uses internet to work. The fan is made for the ones that can't have the accessibility to air con or a bigger fan so they just connect it to their laptop and that's it. It also is made to stop spinning whenever it starts getting cooler like if it's becoming night time and the temperature decreases for about 5 °C the fan stops spinning for itself so it doesn't distract the user while being used.

Time management:

The project must not take more than 27 weeks as there isn't enough time to plan and manufacture.

Who	What	When	Where	Why
Anyone who uses a lot a laptop and doesn't have access to air con.	It's a fan that turns on depending on the temperature.	Whenever it's hot.	It can be used anywhere as long as you have a USB socket.	So there's no need to turn on and off the fan when the weather is unpredictable.

Bimester 3									
Criteria	Week 1	Week 2	Week 3	Week 4	Week 5	Week 6	Week 7	Week 8	Week 9
Content, analysis and design brief									
Research and Specifications									
Folio improvements									
Bimester 4									
Criteria	Week 1	Week 2	Week 3	Week 4	Week 5	Week 6	Week 7	Week 8	Week 9
Research and Specifications									
Design Ideas									
Development									
Exams & Trips									
Folio improvements									
Bimester 1									
Criteria	Week 1	Week 2	Week 3	Week 4	Week 5	Week 6	Week 7	Week 8	Week 9
Manufacturing									
Planning									
Folio improvements									
Bimester 2									
Criteria	Week 1	Week 2	Week 3	Week 4	Week 5	Week 6	Week 7	Week 8	Week 9
Evaluation									
All work final submission									
Theory and Revision									
Folio improvements									
Bimester 3									
Criteria	Week 1	Week 2	Week 3	Week 4	Week 5	Week 6	Week 7	Week 8	Week 9
Mocks									

QUESTIONNAIRE

This part of the project is the questionnaire, which is when I ask a specific number of people from the audience of my product, to have a guide in which preferences the aimed public has. I asked different questions about different fields of the fan like cost, size, looks, etc. In this poll I asked 30 people from the school, roundabout 16 years, 15 boys and 15 girls as my product is aimed for both sexes.

I wanted to know if the aimed audience preferred the fan to be powered by a USB entrance, a socket, or powered by batteries. The results were pretty unbalanced as USB had much more than the socket and batteries. 87% people chose USB, while socket and batteries were 6.5% each. This question was the confirmation of how I was going to carry on the project as the first plans were to make it USB powered. I think people preferred USB in general more than the others as if it was going to be powered by batteries it wasn't going to be economic neither environmental-friendly as the batteries itself would've cost more than the actual product plus the use of batteries isn't good for the environment as they create too much waste to the atmosphere. Socket wasn't successful neither maybe because the cable to be next to a socket must be really long so there is a reach to the persons head and it also wouldn't be too practical.

Which entrance would you prefer for powering the fan?

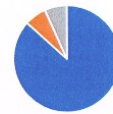

■ USB ■ Batteries ■ Socket

1. Which entrance would you prefer for powering the fan?

USB	Batteries	Socket
26	2	2

I wanted to know if the aimed audience preferred the fan to be from 1cm-10 cm, 11cm-20 cm or 21cm-30 cm. This was a crucial question as I wasn't sure of which size my audience would prefer and therefore how big do I needed to make the fan. The most popular option was from 1cm-10cm which had 50% of the votes. The next one had 27% which was 11cm-20cm and the least popular was 21cm-30cm with 23%. The results in this question were relatively close in comparison with the others. The fan will be around 10cm in length.

What size would you prefer the fan to be?

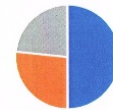

■ 1cm-10 cm ■ 11cm-20 cm ■ 21cm-30 cm

2. What size would you prefer the fan to be?

1cm-10 cm	11cm-20 cm	21cm-30 cm
15	8	7

I wanted to know if the aimed audience preferred the fan to start spinning at 26 °C, 28 °C or 30 °C. I asked them at what temperature approximately they would start to feel uncomfortable approximately, as someone isn't looking at a thermometer all the day. Most people said 26 °C, which is 63%. The second most chosen was 28 °C with 27% and the least popular was 30 °C with 10%. This will make me chose de temperature for the fan to start spinning of about 27 °C so there is more people which would like to buy it.

At what temperature approximately do you start to feel uncomfortable?

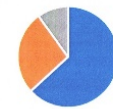

■ 26 °C ■ 28 °C ■ 30 °C

3. At what temperature approximately do you start to feel uncomfortable?

26 °C	28 °C	30 °C
19	8	3

I wanted to know how much the aimed audience would be keen to pay for the fan. This question will guide me on how much limited the price of production would be in order to make some profit. The leading option in this poll was \$1-\$10 which had 57% while the second one was \$11-\$20 with 37% and the last one was \$21-\$30 with 6% of the votes. I personally thought that \$1-\$10 was going to have much more as I can't really see anyone spending more than \$10 on a fan. My cost will be limited to no more than \$5 of production cost so I can make enough profit and a good number of sales.

How much are you keen to pay for the fan?



Legend: \$1-\$10 (Blue), \$11-\$20 (Orange), \$21-\$30 (Grey)

I wanted to know if the aimed audience preferred what colour they wanted the fan to be. This question wasn't that important at all as the fan colour would not affect the circuit (unless it's black). The most chosen was red with 37%, the second most chosen one was white with 27%. The third most popular was black with 20% and the least chosen was blue with 17%. After this question I have decided that the fan is going to be red, not just because it was the favourite but also because it can't be black as black would heat up the thermistor quicker than the other products and what the audience wants is a fan that starts spinning at a certain fixed temperature, not something that is supposed to spin at 27 °C and not 25 °C just because the colour of the fan overheats the thermistor.

Which colour would you prefer the fan to be?



Legend: White (White), Black (Black), Red (Red), Blue (Blue)

I wanted to know if the aimed audience preferred the fan turbine to have a case or to be wide open. The results showed that most people wanted to have the fan without a case with a 60% while the other 40% chose a fan with a case. Therefore, the fan will have no case also because it's more simple to have if it is connected by a USB entrance, as well as it will need less mass on the stem as without a case the fan will be lighter and hence it will need less force to maintain its own weight. The no case option also links with the next 2 questions because if it doesn't have a case then the turbine can't be made out of acrylic and less steel due to safety reasons.

Would you prefer the fan with or without a case?



Legend: With Case (Blue), No Case (Orange)

I wanted to know if the aimed audience preferred the fan turbine to be made of which material. The most liked one was cupboard with 57%, then acrylic with 40% and steel with 3%. The fan turbine will be made out of cupboard because it's too dangerous to have a steel or acrylic turbine spinning at really high speeds as if you accidentally put your finger on the turbine you might get seriously injured. Also because as acrylic and steel are heavier, they will take more energy to spin while cupboard is really light and cheap.

Which material would you prefer the fan turbine to be made of?



Legend: Acrylic (Blue), Cupboard (Orange), Steel (Grey)

I wanted to know if the aimed audience preferred the fan to be held on the air by a steel pipe or if they wanted it to be resting on a surface. 64% of people chose it to be on the air while the other 36% chose it to be on a surface. It would make more sense if the fan would be held on the air, without a case with the turbine made out of cupboard as all of these top options connect while the other alternatives like cased fan with an acrylic turbine having to be supported on a surface. The first one makes more sense plus it's the most popular one.

Where would you prefer the fan to stand?



Legend: In the air (Blue), On a surface (Orange)

4. How much are you keen to pay for the fan?

\$1-\$10	\$11-\$20	\$21-\$30
17	11	2

5. Which colour would you prefer the fan to be?

White	Black	Red	Blue
8	6	11	5

6. Would you prefer the fan with or without a case?

With Case	No Case
12	18

7. Which material would you prefer the fan turbine to be made of?

Acrylic	Cupboard	Steel
12	17	1

8. Where would you prefer the fan to stand?

In the air	On a surface
19	11

PRODUCT ANALYSIS

My project is a fan that spins depending on the room temperature. It is connected by USB and will have a metal pipe holding the fan. The propeller will be made out of cupboard so there isn't risk of injury if you touch it while it's operating. The fan turbine and motor will be held in the air by a steel pipe which is really flexible and resistant.

The research is a crucial part on my product as it is the guideline to the decisions I make about the aesthetics. This will optimise the reachability my project as it is based on the direct opinion of the large public it is aimed to and not just my personal opinion.

The good thing of my product is that it can be really helpful whenever you are using much your laptop and you can't have the luxury of connecting and disconnecting the fan because of the temperature change. The weakness of my product is that sometimes the thermistor's recording temperature could be easily failing as there are a lot of things that count on the temperature recorded as the fan temperature itself.

The data I have collected will be used as a guideline to the manufacturing and design to meet the most of the likes and needs of the customers.

Method/ Page title	Description of the method	Analysis and decisions
Product Analysis	Description:	What the research showed me:
	Why is this research important	How I will use this data
	Strengths	
	Weaknesses	

FAN PRODUCT RESEARCH

Name: CTL power Handheld Fan, Portable Mini Mistting Personal Cooling Fan with Soft Wind and Ultra-quiet for Travel, Home, and Office (Blue)

Cost: \$17.99

This portable fan is a really good product as it is a good portable temperature cooler. However, the point of my product apart from being temperature resistant, was that it should be aimed to people which work using a laptop. This means that it has to be charged by a plug as well as it is would reduce the productivity of work tremendously as it has to be held by a hand to work.



Name: SIMBR Portable USB Mini Desk Fan with Quiet Centered Wind (6", Black)

Cost: \$12.99

This portable fan meets some specifications for my audience. It proportions a powerful air current as well as a movable. Some of the problems this fan has is that although it has a rack to cover the steel turbine, it is really dangerous if an unwanted small object gets inside as well as a finger, which can generate a serious injury. This fan is also really big and heavy and takes loads of space when it would be best if the fan takes the least amount of space possible.

Name: ARCTIC Breeze Mobile - Mini USB Desktop Fan with Flexible Neck and Adjustable Fan Speed | Portable Desk Fan for Home, Office | Silent USB Fan | Fan Speed 1700 RPM - White

Cost: \$7.99

This fan is a rough idea of what I want to make as my final product. It meets most of the specifications as it is ergonomic as it has the steel pipe which makes it flexible, resistant and lightweight. It also has some Plastazote fins which makes a powerful enough air current. The product is also powered by a USB. Even if this design is much better than the other 2 in respect to the client, this one doesn't change depending on the temperature.

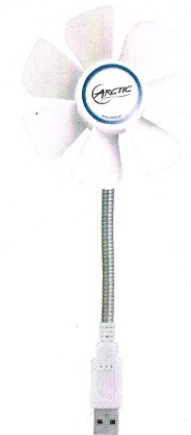

MATERIALS RESEARCH

Plastics

Acrylic:

Acrylic is a plastic that is used to make signs, cases, replace glass, etc. It is used to replace glass as it has a really high light transmission. It also has some variability on colours. The only problems are that it is pretty expensive as one sheet of acrylic of 0.118 in. x 48 in. x 48 in. can cost from \$150-\$200 and also it is pretty stiff and brittle. It's really suitable to use the acrylic on my fan as it is attractive and accessible from school. If my project finishes having a case, it can be made out of acrylic.

Polystyrene:

Polystyrene is a type of plastic which is used mainly for vacuum forming. Polystyrene is strong, tough and it resists scratches. A problem is that it is pretty stiff. It costs around \$2000 the ton so it costs around \$2 per kg. which is relatively cheap. There is a possibility for me to use polystyrene as if I get to make a case it would be cheaper than acrylic and more durable. I would make a case vacuumed formed.



Metals

Tool steels:

Tool steels are a type of metal which is an alloy composed mainly on steel with cobalt, molybdenum, tungsten and vanadium. They are used to make mainly long and tubular products and flat products. It is really flexible plus they are fairly strong and durable. They are also don't conduct electricity. It is quite cheap as it costs around \$ 990.0-1040.0 / Ton, which is like \$1 for each kg. In my project I would use it to be the stem between the USB and the fan. As it is really flexible it can change the direction of where the fan is pointing towards really easily.

Copper:

Copper is a type of metal which is used for roof coverings, plumbing, electronic components and plumbing. Copper is a metal which is a very good conductor of heat and electricity. It is really cheap. It is determinant for my project as it will be in the electrical circuit. It will be inside the wires.



Woods

MDF:

MDF is a type of wood which is man made, is recycled wood. It is mainly used to make cases to then vacuum form, decorative projects, etc. It is used as it is really cheap and fairly durable. A sheet of 3mm x 35cm x 40cm costs around \$/.2 at most. In my project it will definitely not be part on the final product but still can be used to mould the fan case if I get to use a case.

Plywood:

Plywood is a type of wood which is man made, is recycled wood. It is mainly used to make cases to then vacuum form, decorative projects, etc. It is used as it is really cheap and fairly durable. A sheet of 3mm x 35cm x 40cm costs around \$/.2 at most. In my project it will definitely not be part on the final product but still can be used to mould the fan case if I get to use a case/



SPECIFICATIONS

Specification	Description	Justification
Cost	The cost of the manufacturing must not be more than \$4.	I asked my clients how much are they keen maximum to pay and the majority said no more than \$10 plus I want to make good profit.
Time	The project must not take more than 27 weeks.	If it takes more than 27 weeks there is not going to be enough time to manufacture.
Client	The product must be aimed and designed for people older than 15 years, all genders, that tend to work or use a laptop a lot especially on hot seasons.	If I don't aim the fan for them the project will be pointless as that audience is really big and diverse and therefore more people to sell.
Function	The fan turbine must start spinning at 27°C and it also must be light enough to spin with around 3V of energy.	I asked the audience at which temperature they started to feel uncomfortable and the average temperature was 27°C so it is when the fan will need to start spinning. The fan must work with around 3V of energy so it doesn't take must energy from the laptop when it is in use.
Environment	The fan must not use batteries.	The use of batteries on the fan will not just be unpractical and expensive at long term, but also will damage the environment much more than if the energy is just taken from the USB entrance.
Aesthetics	The fan will have a USB entrance followed by a tool steel metal pipe which will have the wires inside, and at the top a motor covered on acrylic and a cupboard turbine.	Those looks where, the ones which fit the popular options on my research.
Materials	The stem of the fan will be made out of tool steel and the turbine out of cupboard.	The stem needs to be flexible and durable and strong enough to hold the turbine and motor without any complications. The turbine needs to be made out of a durable and unharful material.
Safety	The fan turbine must be mad out of cupboard.	If the turbine is made out of another material like steel it would be dangerous as you can injure yourself if you touch it will its spinning.
Ergonomics	The stem must not be rough	If the stem is rough then it will be uncomfortable to manipulate directly with a hand. It can also harm the user.
Finish	The finish must be a bright red acrylic that surrounds	I asked the audience which colour they would prefer

DESIGN BRIEF #1&2

The thermistor will be at the top so it doesn't get affected by the wind created by the turbine or the heat radiated from the body

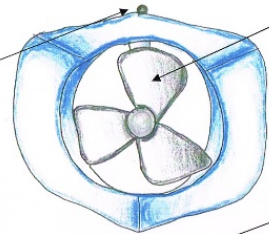

Large steel fan so it creates a big air current onto the air and act as a normal fan.

Big cube-alike shape so it can be stable on a flat surface. It is held by batteries so it is not a good idea as it would take a large amount of energy to spin.

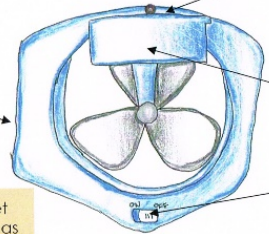

Flat top so things can be put on top

Plastic supporter so it can be held on vertical surfaces.

On/Off switch has a grip for easier manipulating. The switch will be sliding as it occupies less surface.

This design doesn't meet almost any specification as its big an unsafe

Plastazote fan turbine so it doesn't harm or injure the user whenever is spinning. Also it is a light material and takes

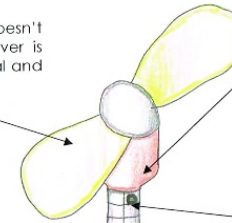

Filletted rounded edges to avoid the user from getting harmed and injuries.

Flexible metal pipe to change the air current direction made by the fan. This way it makes it really ergonomic and adaptable to different situations.

Thermistor is below the fan so it does not get affected by the fan.

USB entrance to supply power for the fan

Filletted rounded edges to avoid the user from getting harmed and injuries.

This design meets the most of the specifications and has an amazing look which is the reason why I'm choosing thus design to improve forward

P	M	I
It is easily manipulated and it is comfortable to refresh one person. The turbine is made out of cupboard so it is not harmful when touched.	It doesn't meet the expectations of the audience as it is ran with batteries and its use is for other causes than feeling uncomfortable while working.	Give it a USB entrance for charging it. Also stabilizing the base so it can stand on a plain surface.

Specification	Meet of requirements
Cost	60%
Time	100%
Client	30%
Function	65%
Environment	40%
Aesthetics	70%
Materials	70%
Safety	20%
Ergonomics	85%
Finish	70%
Scale of	N/A

P	M	I
It is thin and flexible so it can satisfy the user if bent at different angles. It is also sufficiently small to fit on a USB entrance but not big enough to look modern and dynamic. The USB entrance takes away the need of batteries and facilitates the accessibility for the user when using a	The metal pipe might have to be imported which may take a week to get here. The Plastazote turbine could get easily damaged as it is a weak material.	Try to use another material than acrylic so it doesn't harm the environment.

Specification	Meet of requirements
Cost	70%
Time	100%
Client	85%
Function	85%
Environment	60%
Aesthetics	90%
Materials	80%
Safety	100%
Ergonomics	95%
Finish	80%
Scale of	N/A

DESING BRIEF #3&4

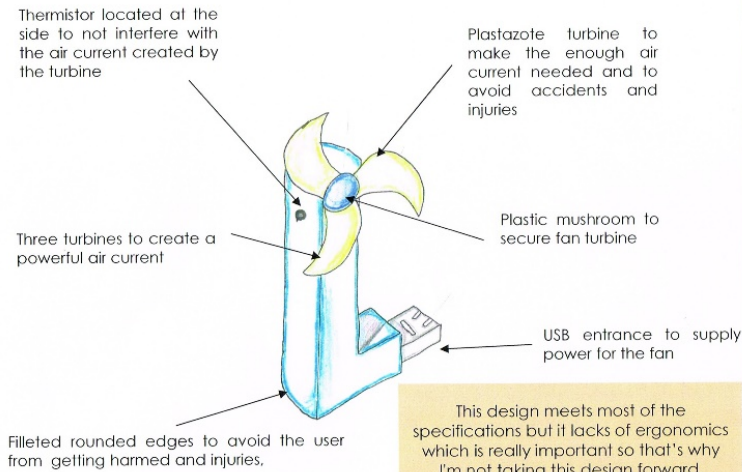

This design meets most of the specifications but it lacks of ergonomics which is really important so that's why I'm not taking this design forward.

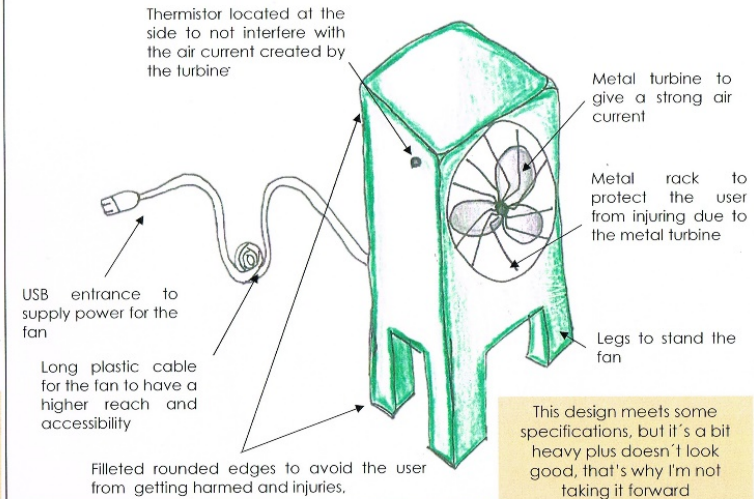

This design meets some specifications, but it's a bit heavy plus doesn't look good, that's why I'm not taking it forward

P	M	I	Specification	Meet of requirements	P	M	I	Specification	Meet of requirements
The turbine is made out of Plastazote so it is not harmful when touched. The design isn't excessively big as it is the right size to give a strong air current without much use of space.	It can only point perpendicularly to the laptop USB entrance so it is not very accessible always.	Give the possibility for the fan to move and increase the range of accessibility.	Cost	70%	The current gave by the fan is strong so it satisfies the comforts of the user. The long cable connected to the USB gives mobility and accessibility for the fan.	It is to big and heavy which makes it disturbing to a certain extent if you are working. The metal fan has a high risk of injuries even if the security rack is there.	Try to reduce the size and weight of the whole fan. Also to try and change the turbine material because metal fins spinning at high speed isn't safe at all.	Cost	80%
			Time	100%				Time	100%
			Client	70%				Client	75%
			Function	90%				Function	90%
			Environment	60%				Environment	60%
			Aesthetics	65%				Aesthetics	50%
			Materials	85%				Materials	80%
			Safety	85%				Safety	80%
			Ergonomics	20%				Ergonomics	65%
			Finish	80%				Finish	70%
Scale of	N/A	Scale of	N/A						

DESING BRIEF #5&6

The thermistor will be at the top so it doesn't get affected by the wind created by the turbine or the heat radiated from the body

Fan it's made out of cupboard because it is lighter and therefore less energy is needed to be moved, it is really cheap and it is not harmful whenever travelling at high speeds.

Reinforced strip to hold the turbine making it not touch anything.

Polystyrene case so it resists scratches and it is strong. A problem would be that it is pretty stiff

On/Off switch has a grip for easier manipulating. The switch will be sliding as it occupies less surface.

Rounded edges so it is easily held by a hand and not harmful. The main problem is that it wouldn't be stable standing.

This design meets most of the specifications, has a really good and modern look and has a clear function. Nevertheless it isn't designed to working people using laptops so I'm not developing it more,

The thermistor will be at the top so it doesn't get affected by the wind created by the turbine or the heat radiated from the body

Metal turbine so it gives out a stronger air current and it is also resistant to scratches.

Security steel rack so it protects things entering the fan

Polystyrene case so it resists scratches and it is strong. A problem would be that it is pretty stiff

On/Off button is there so when being held by a hand it won't be accidentally pressed.

Whole on the middle so it can be held by a hand easily.

Rounded vertex to give a cool and modern design. The main problem is that it wouldn't be stable standing.

This design meets most of the specifications and looks modern. However it isn't designed to working people using laptops so I'm not taking it to improve it forward.

P	M	I
It is easily manipulated and it is comfortable to refresh one person. The turbine is made out of cupboard so it is not harmful when touched.	It doesn't meet the expectations of the audience as it is ran with batteries and its use is for other causes than feeling uncomfortable while working.	Give it a USB entrance for charging it. Also stabilizing the base so it can stand on a plain surface.

Specification	Meet of requirements
Cost	70%
Time	100%
Client	30%
Function	90%
Environment	70%
Aesthetics	85%
Materials	80%
Safety	90%
Ergonomics	90%
Finish	70%
Scale of	N/A

P	M	I
It is easily held and really comfortable to be used a lot of time. The steel fan makes the air current output being stronger.	It doesn't meet the expectations of the audience as it is ran with batteries and its use is for other causes than feeling uncomfortable while working. Also is not very safe having a metal turbine as even if there is a rack, it might be dangerous.	Give it a USB entrance for charging it. Also stabilizing the base so it can stand on a plain surface. Changing the fan will also be suitable as a metal turbine is not safe at all.

Specification	Meet of requirements
Cost	60%
Time	100%
Client	40%
Function	90%
Environment	60%
Aesthetics	85%
Materials	70%
Safety	80%
Ergonomics	95%
Finish	75%
Scale of	N/A

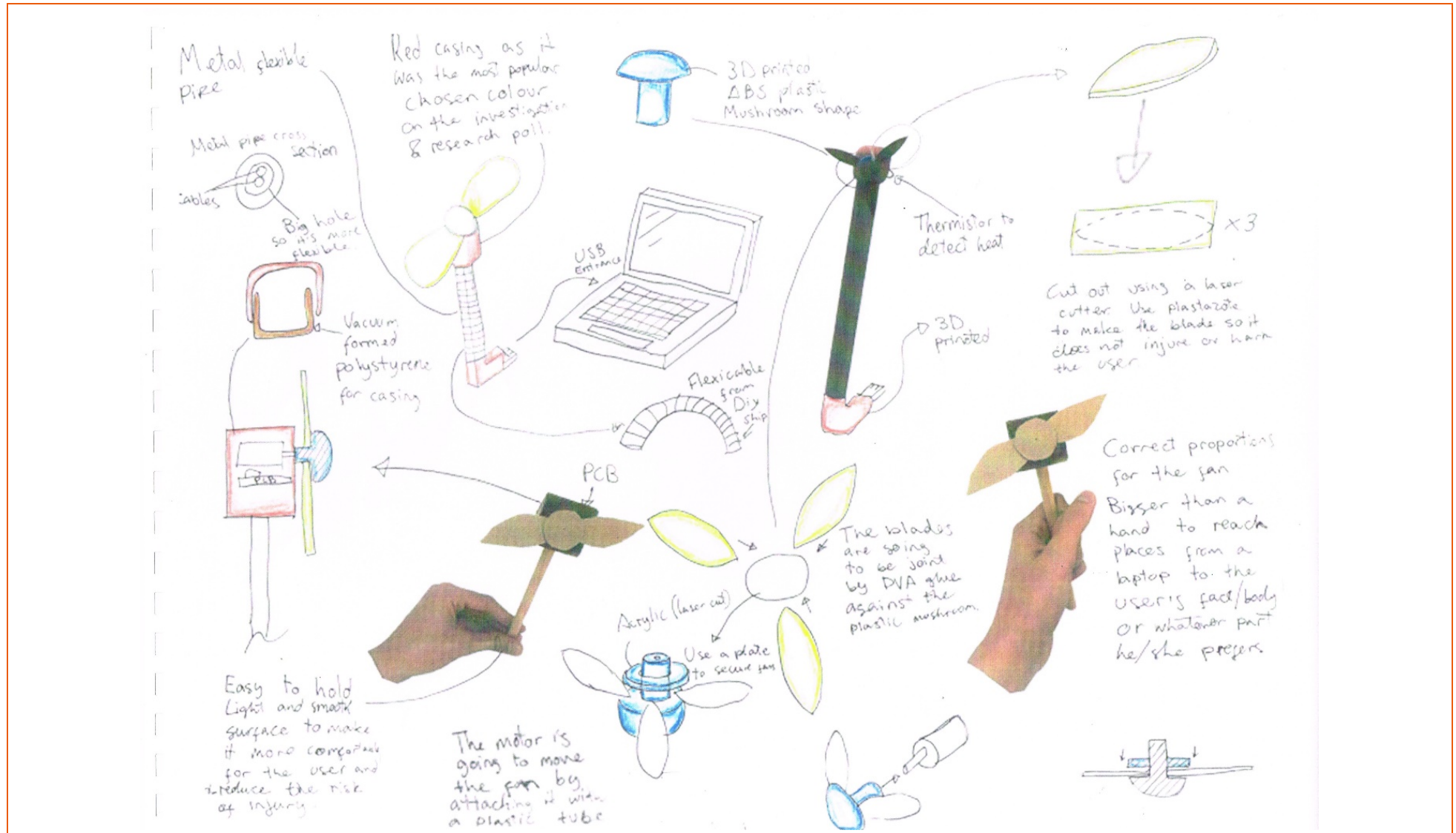

DESIGN PROPOSAL

The casing of this design is based on a 5-side cube alike shape, with round filleted edges. It will be stuck at the top of the flexible metal pipe and it will hold the motor inside and the plastic mushroom and fan turbine outside. It will be red bright coloured so it is attractive at first sight for the client. It will also be red as it was the most favourite colour on the research page. The case should be as small as possible where the motor can be fitted so it has a dynamic and modern look.

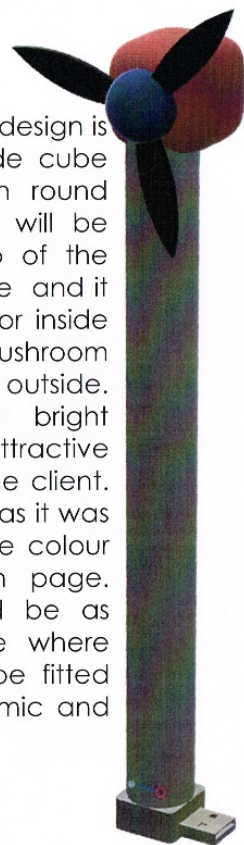

Cost	The casing isn't going to be much expensive as it is going to be vacuumed formed from MDF wood which is really cheap.
Client	The product must be aimed and designed for people older than 15 years, all genders, that tend to work or use a laptop a lot especially on hot seasons.
Function	The Function of the casing is designed to hold justly the most components as the motor and to hold the mushroom with the fan turbines.
Environment	The mould of the case will be vacuumed formed from MDF which means that it is environmentally friendly as it is using the leftovers of wood used for other projects.
Aesthetics	The case will be big enough to hold the motor and the rest of components apart from being able to hold the plastic mushroom to maintain the turbine in place. Nerveless it must be small enough to not occupy unnecessary space to make the design look modern and dynamic.
Materials	The case of the fan will be vacuumed formed out of polystyrene from an MDF mould. The case will be made stuck with the other pars with PVA glue.
Safety	The case will have round filleted edges to avoid the possibilities of hard edges to injure the user. Also the use of polystyrene is cutting off the risk of the case to be magnetized and therefore shock electrically the user.
Ergonomics	The case will have filleted and round edges so when grabbed to change the fan direction, it does not harm or uncomfort the user.
Finish	The case finish will be a bright red acrylic as it was the most chosen one on the polls as the favourite colour for a fan. It will also be bright to be strikina at first siaht to call the user's attention easily.

DEVELOPMENT OF CIRCUIT

I will use Yenka to make the circuit modelling, which is a CAD circuit modelling program. This is the first circuit which is the most basic one for running the fan. The circuit I'm making is a fan which must be turned on at 27 °C. It has a basic 9V battery, a thermistor and a motor. I could notice that it worked but the motor moved really slowly when the fan to be effective must rotate really dynamically.

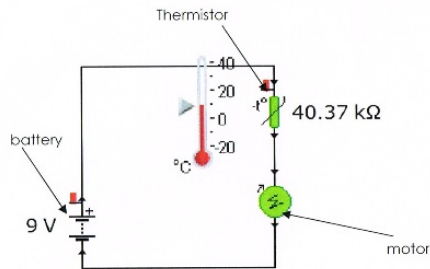

The next circuit was added the motor with some to see if it work. The motor spanned really fast which meant the fan was ready for use.

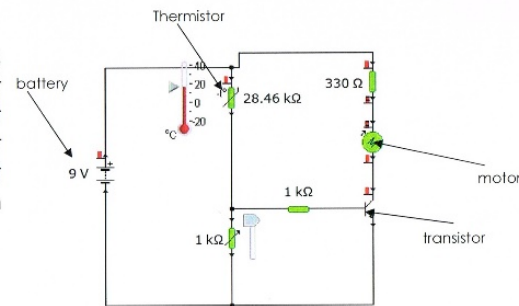

The next circuit was added to variable resistors and an LED to see if it was working properly. I also added a transistor to increase the efficiency of the circuit and another parallel variable resistor to make the fan turn spin when getting hot and not when getting cold.

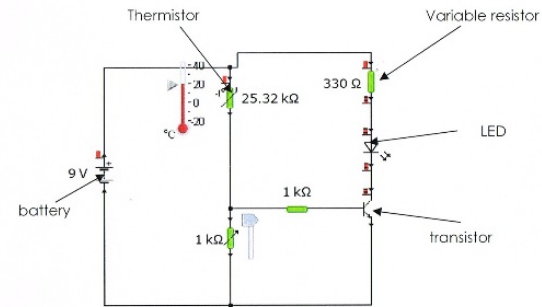

The final circuit after it worked properly, there was a problem as the source of energy needed must have been 5V as it is the maximum voltage a USB can resist is 5.

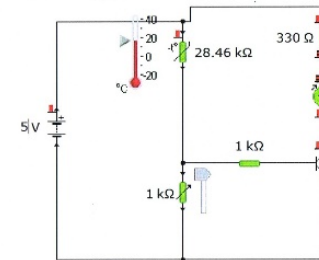

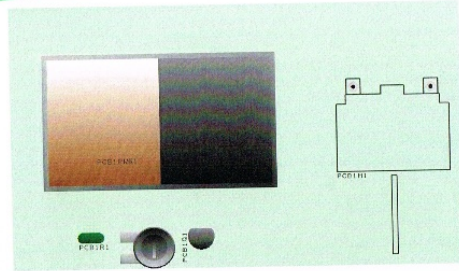

The next circuit was added to variable resistors and an LED to see if it was working properly. I also added a transistor to increase the efficiency of the circuit and another parallel variable resistor to make the fan turn spin when getting hot and not when getting cold.

The final circuit is finally exactly what I wanted and what would fit the project. The 5V battery is superb as it is the voltage the USB can supply and it works totally fine. The fan will start spinning when the thermistor detects more than 27 °C it will let the electricity flow through the circuit which will make the motor (fan) spin.

The final circuit after it worked properly, there was a problem as the source of energy needed must have been as it is the maximum voltage.

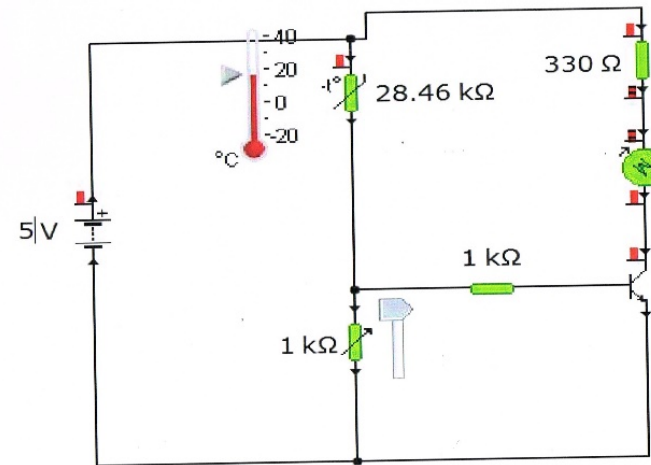

GANTT CHART

A Gantt chart, commonly used in project management, is one of the most popular and useful ways of showing manufacturing steps showed against time. On the left of the chart is a list of the steps to follow on the manufacturing and along the top there is a suitable time scale. A Gantt chart is used to measure time on the manufacturing wisely so some parts aren't rushed or skipped. In this way is also easy to show how I did control the time on the manufacturing of the project which was successfully done

On these Gantt charts I am showing that every week we had 2 lessons, of 80 minutes each, which each time another type of work had to be done. In this way I could arrange time and make sure I don't take too long or too short on each part.



GANTT CHART

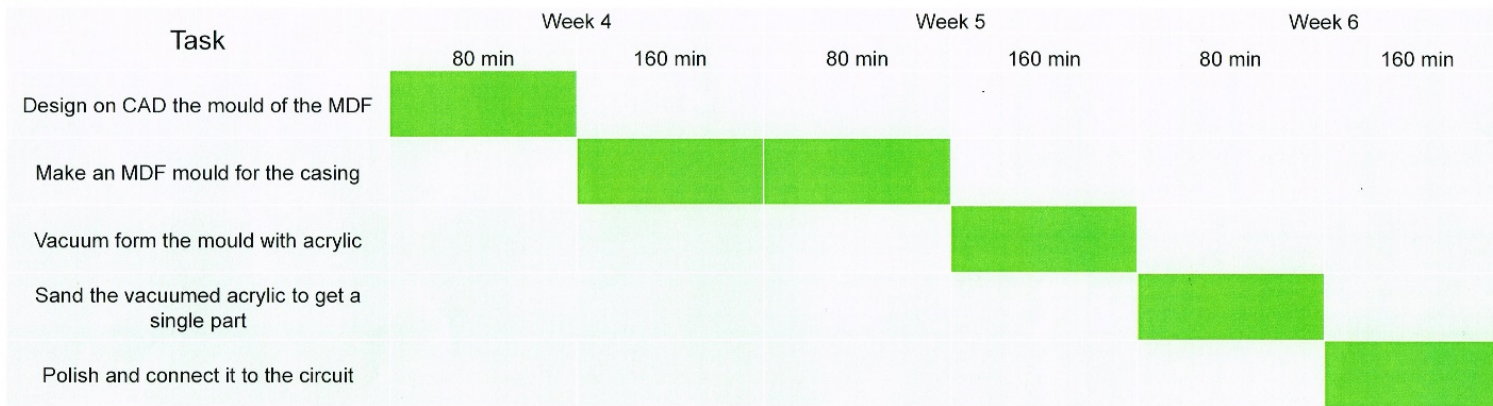







PRODUCTION PLAN CIRCUIT

Operation	Tools	Materials	Quality Check	Time
Design MDF mould for fan case	Fusion 360, a computer program	-	I have to make sure that the design I make is possible to vacuum form	80 min
Vacuum form the MDF mould onto acrylic	Vacuum forming machine	Acrylic sheet	I have to check that there is no dust or there are no impurities on the acrylic.	80 min
Sand the acrylic case to get one single part	Sanding paper	-	I must not sand the edges too hard because then the shape I changed and the fan would lose its symmetrical look.	80 min
Design on CAD	2D design a computer program	-	To check that everything is fine I have to assure that the measurements are right	80 min
Print on cupboard to prevent measurements	Laser cutter	Cupboard	To check if the measurements done in the CAD were working, once again I have to print it off on cupboard to check if everything really does fit.	80 min
Drill holes on the case	Pilar drill	-	I must check that the holes are the perfect size so the cable and thermistor popping out are not shown	80 min

PRODUCTION PLAN CASING

Operation	Tools	Materials	Quality Check	Time
Design circuit on CAD	Yenka program on computer	-	Here I would check that in the program that the circuit is fully functioning and simple.	80 min
Get the components for the circuit	-	-	I have to chose every single piece of equipment wisely to prevent mistakes and dysfunctions on the project.	80 min
Solder the components to the PCB	Solder iron	Solder	I must check that solders are neatly separated to prevent malfunctions on the project because of crossed cables	240 min
Testing and perfecting the circuit	-	-	I needed to check if all of the circuit was fine and optimise it so the product improves each time.	80 min

RISK ASSESSMENT

Tool	Photo	Risk	People Affected	Safety measure
Soldering iron		The solder is about 400°C which is an instant burn, apart from the molten iron which can stick to your skin as well.	Me	Use this tool responsibly, not using headphones, wearing an apron and using safety glasses.
Tensol 12 glue		This chemical is carcinogenic and very toxic if inhaled a lot.	Me and everybody nearby	Use in a ventilated room and try to remain it closed for as long as possible.
Wood Miller		This machine has a blade which goes really fast and can instantly cut your skin at least with the most minimum contact.	Everybody near it	Put a big sign or do not let anyone come near this machine while in use.
Laser Cutter		The laser cutter cuts with a strong beam of light which means that is really hot so if you try to take your printed stuff right away it might burn you. Also some fumes it produces are toxic.	Everybody near it	Try to put a mask on and wait some time after the laser cutter finished printing so it can cool down a bit.
Vacuum former machine		The vacuum forming machine produces a high amount of heat to melt plastic, which means that in contact with your body can burn you.	Me	After vacuum forming wait a while for the machine and the plastic to cool down a bit.
Sanding paper		The sanding paper has a rough surface which after moving it really fast, if it touches your skin it can damage it.	Me	Try to be careful when I'm sanding making sure I don't sand my finger.
Pillar drill		The drill moves really fast and your hand is exposed. Also some bits can land on the user's eye.	Me	Use safety goggles, an apron and always be careful while using it.

CUTTING LIST

Circuit			
Component	Quantity	Cost per unit (\$)	Total Cost (\$)
LED	1	0.5	0.5
Thermistor	1	0.01	0.01
9V Battery	1	4	4
Fan	1	5	5
PCB	1	6	6
Wire (400mm)	2	0.2	0.4
Resistors	4	0.2	0.8
Solder (400mm)	2	1	2
Transistor	1	0.5	0.5
		TOTAL COST	19.21
Casing			
Acrylic Sheet	2	5	10
Tensile Glue (per litre)	0.2	20	4
MDF wood	2	0	0
		TOTAL COST	14

Total cost (\$)		
Circuit	19.21	28.21
Casing	9	

MANUFACTURING

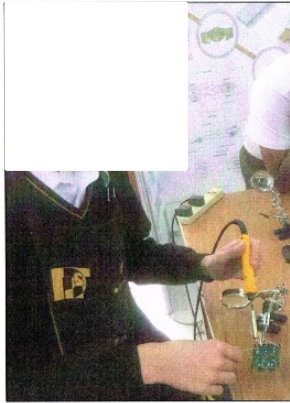

First of all I had to make the circuit by soldering it with soldering iron, this took really long.

Then when it is cut, I had this little piece left which was smaller than my hand



Then I had to create the design in Fusion 360 according to the sizes of the fan because this case was going to protect it.

I had to put this onto the vacuum former, which has on top a red sheet of acrylic that has a nice colour.



After I made my design I built an MDF with bigger dimensions to then be cut onto the mould.

This small piece was left which is good because is the last part for this part of the case.

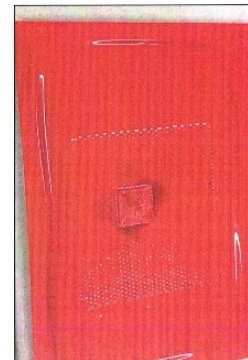

Then I put it onto the wood miller to cut the mould.

After I got it out I had to sand it for really long until I got it separated into two different pieces. This sanding process took long.



MANUFACTURING

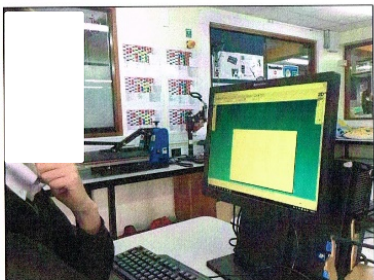

First of all I had to make the casing design on CAD (2D design)

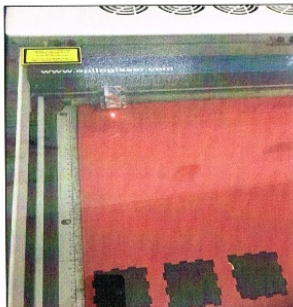

The design was really good so I put it onto the laser cutter and cut it so I get 6 singular pieces which form a box



I had to figure out the forming of the box to then paste it.

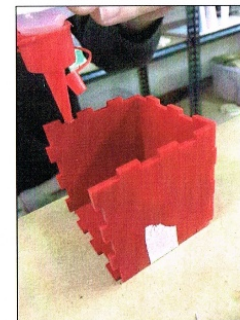

After I figure out the sides, I pasted it with silicon so it is resistant.

I used tape to secure it while it was drying out. I pasted everything but one side as the circuit was going to inside.

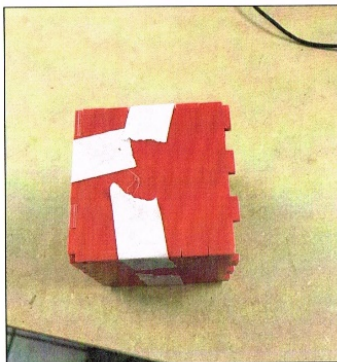

After the box was made I had to add some holes in it so the thermistor and cables pop out.



I used this screw van to add screws afterwards to check the circuit whenever I want easily.

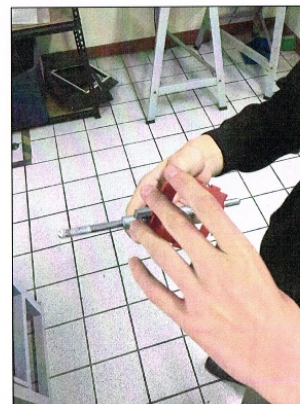

The next part was to make this little monomer pieces which were going to get the fan, these were 3D printed.

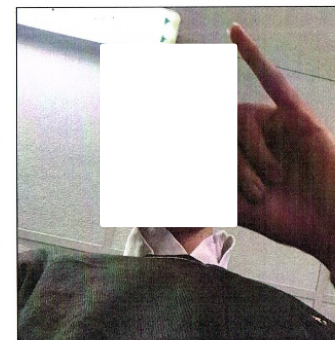

MANUFACTURING



First of all I had to sand al of the little parts I used, as they were 3D printed they had lots of imperfections.

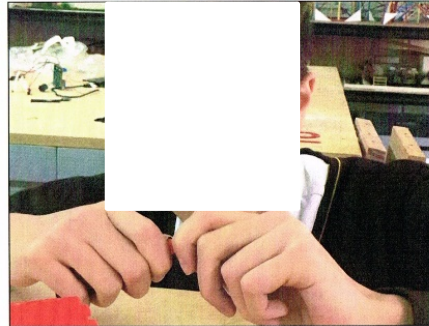

These imperfections had to be sanded away as they needed to fit one another and also to be smooth to increase it's ergonomics.

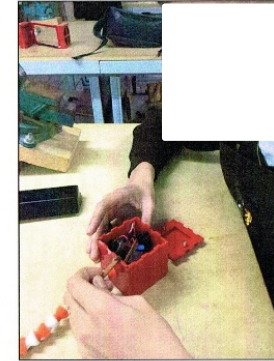

I then pasted the last part of the case, with the PCB inside and the long sustainable 3D printed joint stick had the cables inside going outside the hole on the case. I pasted it with thensol 12 glue.

I had to wait 5 minutes holding it as that is what the glue took to dry off.



And here it is the finished product which works perfectly well!

USER TESTING

Introduction

I had to go around the country to ask for advice to my target audience as they were the area where my product was going to be sold. Really the only requirement is that they use a laptop regularly and that they live on a place that reaches more than 27 °C. I had to look for people different ages, areas of use and genders. I had to travel around two different cities to ask this particular people. A student, a teacher and a hotel manager. They gave me each a comment and a recommendation.

Comments

Cedric, 19 years old, is a substitute teacher that comes from Switzerland. He came to Peru to work as a substitute maths teacher of primary students in a private school called Innova Schools San Miguel. He tends to use a laptop regularly as all of his papers and works for the children have to be on a dynamic and accessible place. He always complained about the hot dynamic atmosphere in the infrastructure of the school, which makes him sometimes wanting to work outdoors, which makes not notable difference at all. The fan was successful in its job as it turned on whenever it got colder it turned off. As he uses his laptop regularly makes him a good reliable tester. As he is a person which represents the young adults necessities, makes him really helpful in this research.

Recommendations

Cedric suggested that the fan was sometimes not helpful at all when it was used outdoors as sometimes the wind disturbs or predominates the air current proportioned by the fan. He also suggested that the fan should also have a longer cable which is connected to the USB for a higher reach and availability as the current one is relatively short which gives a much limited options for the use of the fan.

Cedric, 23, Substitute Teacher

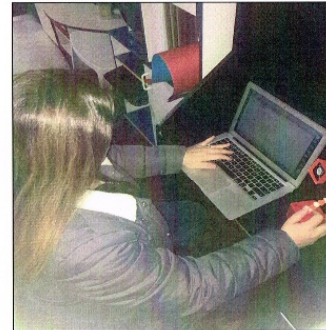

Mandy, 42, Hotel Manager

Comments

Edna, which is 42 years old, is a Hotel Manager Huaraz, which is on the mountain zone of Peru. This is a good example for the audience from dynamic climates as the mountains, as temperatures on the day vary a lot depending on the sun. Edna doesn't use much his laptop as the hotel has still a lot of segments done in paperwork instead of online. The fan where she lives on her trial was successful as temperatures varied a lot through the day so the fan turned on and off several times. The product satisfied her necessities at most whenever the temperature raised. She said she liked the fact that she didn't need to turn on and off the fan several times which saved her some time. However she stated that sometimes having a colourful fan all of the time beside you might be a bit distracting.

Recommendations

Edna suggested that the design should be changed to something that looked more professional to be suitable for an office. She said that that could be possible if the colours where changed to a grey scale fan. This would also support the idea that does not distract much the user while working as the grey scale colours are more likely and similar to be the colours of the desks. Another suggestion was that the USB cable was longer to

Comments

Nikole is a Peruvian S2 student on a public boarding school of distinguishing students "Colegio Mayor Presidente del Perú". She uses a laptop regularly for her high performance work. She told me she has had complains before when high temperatures came on summer and autumn. She has also told me that where she lives the temperatures change a lot throughout the day, so the fan test on her was really helpful and positive as she meets the most specifications for the fan use. She suggested that the fan was a comfortable size and that it produced refreshing air currents.

Recommendations

Nikole suggested that sometimes the fan was a bit comfortless as it didn't always fit on tight spaces like the one at the photo. This might be improved by making the fan be held from the USB entrance, being lighter and more ergonomic for a better use. She also suggested that the deign looked offbeat and like a cliché. This might have been because there wasn't much contrast in the colours which suggests that next time it will have a most complete design.

Nikole, 13, Student



EVALUATION SPECIFICATIONS

Specification	Casing	Circuit
Cost	The casing costed around \$14 which is a bit higher compared to what was expected. This high price was mainly due to the 2 acrylic sheets used for the two parts of the casing.	The price of the circuit was much higher than the expected, as it costed \$19,21, which raised massively the price of the product. This wasn't good as the price was much higher than expected which means less economic winnings.
Client	The product's design makes it attractive for all genders and ages as it has dynamic colour and a professional look.	The average user chose the 27°C mark for the fan to spin. This meets the expectations a it works towards that temperature mark.
Function	The function of the fan case was precise as it didn't occupy large amount of spaces and it covered the circuit and the PCB efficiently. An improvement could be that the case wasn't that big so space and amount of acrylic would be used more efficiently.	The fan was precise for its function as the circuit turned on at 27 °C which was the temperature which was chosen as the average of the people in the research.
Environment	The environment wasn't impacted wisely because of the use of MDF which is basically reused wood. However there are large amounts of energy used to 3D print the connectors and for the wood miller to cut the wood base.	The use of the battery was the only thing that affect harshly the environment, and it was the only thing the circuit didn't must have but there isn't an easier accessible option.
Aesthetics	The case is big enough to hold the PCB and circuit, but doesn't occupy a large surface area when standing. The neck connector is stable enough to hold the fan but light enough to be moved easily.	The use of the USB entrance reduces largely the use of two batteries to just one, and therefore less space is needed for the case.
Materials	The use of MDF was successful to vacuum for the acrylic as it was cheap and the best option possible to use.	The use of soldering was really effective as it joins the circuit in an easy and reversible way.
Safety	The case had filleted edges which where made to prevent accidents and injuries against users, this was successful as it didn't affect the function but prevented lots of possible accidents and injuries.	The fan turbine isn't heavy as well as it doesn't have a sharp edge and therefore if a finger touches t, it will not be likely for the user to harm.
Ergonomics	The neck connector was well sanded so when it was grabbed to change the direction of the fan, it was smooth	

IMPROVEMENTS

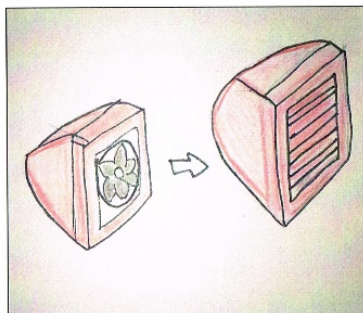

The fan's turbine in the original model where without any cover as they were open to the user. This wasn't very good because some small unwanted object which enters the fan turbine as the fan is turn on, has the possibility of breaking or damaging the circuit. Also it is possible that if a finger accidentally steps on the way of the working turbine it might harm or injure the user.

An improvement or solution to this problem was to create a removable rack made out of acrylic, which would be cut out in a laser cutter. This rack would prevent the damage of unwanted objects as well as protect the user from possible injuries made by the turbine.

The fan's casing for the PCB had its vertices pointy and sharp. This wasn't positive as it reduced the ergonomics of the product as whenever the user wanted to grab the fan it had to beware of the sharp corners to avoid getting harmed. The improvement to this part of the product was to fillet the corners of the cube once its built. This would've been possible with sanding paper, by sanding the corners slightly so there isn't a hole created but enough to reduce the possibilities of any harm or injury.

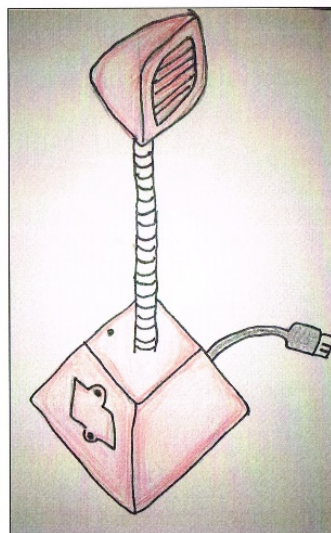
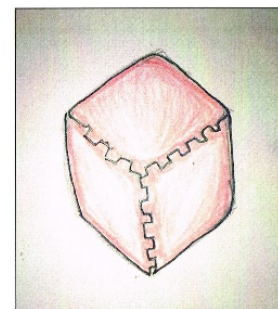

This is the overall look of an improved project all the way. First of all it has a steel pipe instead of the 3D printed neck to hold the fan. This material is more effective to hold the fan as its more steady and much more ergonomic, as well as it takes less time to manufacture. The cubic base that holds the PCB and battery has been changed to a frustum as it is more ergonomic as well as a modern attractive design. This design also contains the acrylic rack to cover the fan as it is safer as well as has a much better look.

3.1 Moderator's assessment of Project C

Criterion	Comments	Mark
1. Identification of a need or opportunity with an analysis leading to a design brief	Relevant investigation with appropriate analysis of the design need, the identification of the intended user(s) and a functional design brief. Questionnaire of user needs.	3 marks out of 5
2. Research into the design brief resulting in a specification	Some relevant research relating to existing products, includes random materials with limited reasoning for their use in the product design. Questionnaire acknowledged in this section. Well-justified specification.	6 marks out of 10
3. Generation and exploration of ideas	Good range of proposals with integration of simple models to help further explore ideas. Appropriate drawing techniques used, with annotations, to explore most of the technical aspects. Ideas are evaluated with some reference to the specification points.	14 marks out of 20
4. Development of proposed solution	Adequate evidence of modelling and trialling, or sketches with annotations to assist technical decisions about the circuit. However, there is limited evidence of development of other features of product.	7 marks out of 15
5. Planning for production	Circuit diagrams are included but no working drawings of product. Cutting list with approximate cost of parts. Detailed sequence of stages of manufacture.	5 marks out of 10
6. Product realisation	The overall outcome is finished to a good standard and functions well. The product meets many of the requirements of the specification. Good photographic evidence of making.	20 marks out of 30
7. Testing and evaluation	Limited evidence of product being tested. Evidence of some evaluation against specifications and third-party comment. Identification of simple strengths and weaknesses of the product leading to some conclusions with proposals for further development.	6 marks out of 10
Total mark awarded		61 marks out of 100

Cambridge Assessment International Education
The Triangle Building, Shaftesbury Road, Cambridge, CB2 8EA, United Kingdom
t: +44 1223 553554 f: +44 1223 553558 e: info@cambridgeinternational.org www.cambridgeinternational.org

Copyright © UCLES March 2018