



Cambridge IGCSE™

CO-ORDINATED SCIENCES

Paper 1 Multiple Choice (Core)

0654/13

May/June 2021

45 minutes

You must answer on the multiple choice answer sheet.

You will need: Multiple choice answer sheet
Soft clean eraser
Soft pencil (type B or HB is recommended)

INSTRUCTIONS

- There are **forty** questions on this paper. Answer **all** questions.
- For each question there are four possible answers **A, B, C** and **D**. Choose the **one** you consider correct and record your choice in soft pencil on the multiple choice answer sheet.
- Follow the instructions on the multiple choice answer sheet.
- Write in soft pencil.
- Write your name, centre number and candidate number on the multiple choice answer sheet in the spaces provided unless this has been done for you.
- Do **not** use correction fluid.
- Do **not** write on any bar codes.
- You may use a calculator.

INFORMATION

- The total mark for this paper is 40.
- Each correct answer will score one mark.
- Any rough working should be done on this question paper.
- The Periodic Table is printed in the question paper.

This document has **16** pages.



1 What is respiration?

- A breakdown of food by enzymes in the alimentary canal
- B breathing to supply oxygen to cells
- C release of carbon dioxide from the lungs
- D release of energy for body activities

2 Which diagram correctly shows the diffusion of carbon dioxide and oxygen between an alveolus and a capillary?

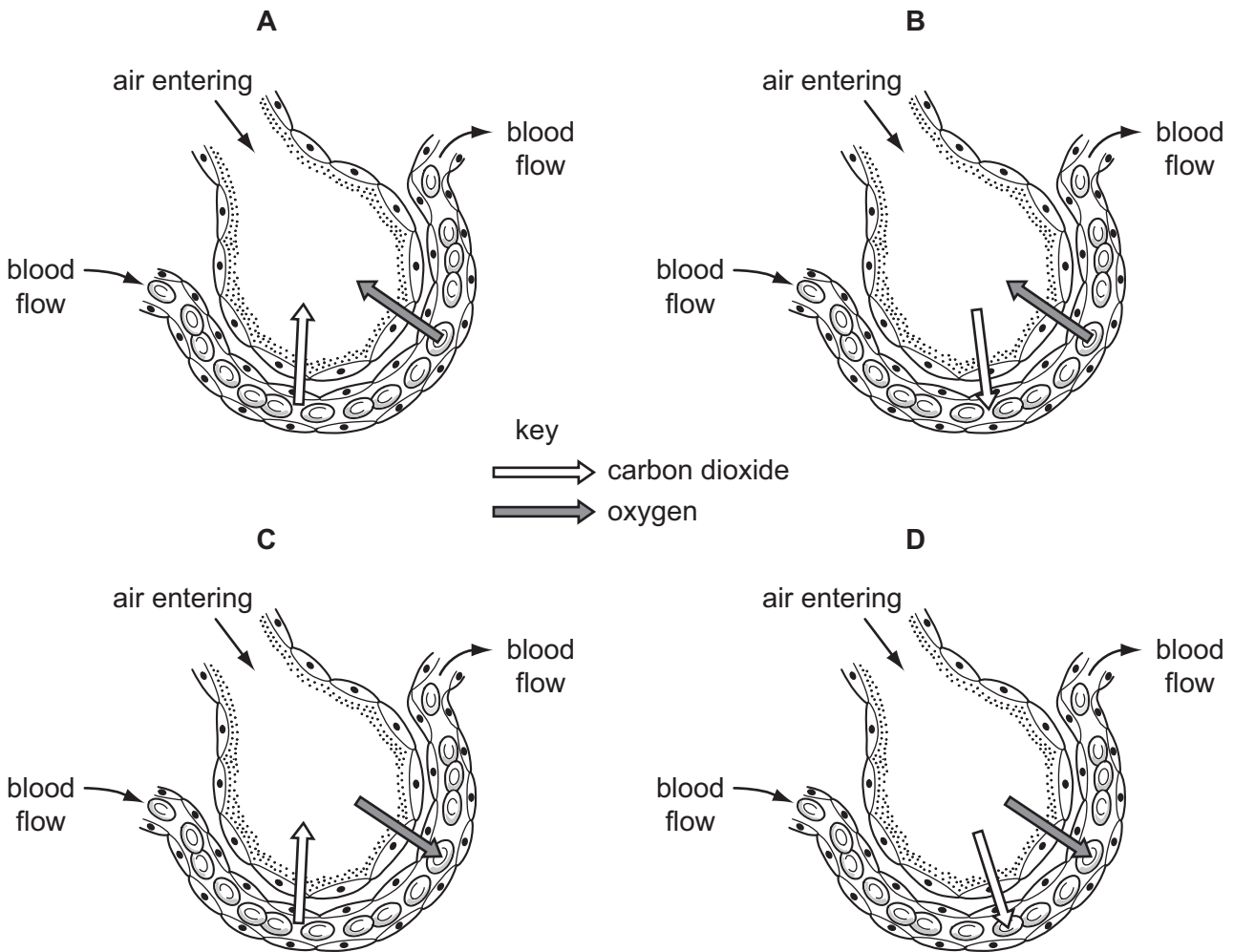

3 Which row matches the nutrient to the chemical elements that it contains?

	nutrient	carbon	hydrogen	oxygen	nitrogen
A	fat	✓	✓	X	X
B	protein	✓	✓	✓	✓
C	starch	✓	X	✓	✓
D	sugar	X	✓	✓	✓

key

✓ = contains element

X = does not contain element

4 Which type of molecule are enzymes?

- A fat
- B carbohydrate
- C protein
- D DNA

5 Four test-tubes were set up as shown.

Which test-tube will contain the most dissolved oxygen after 24 hours?

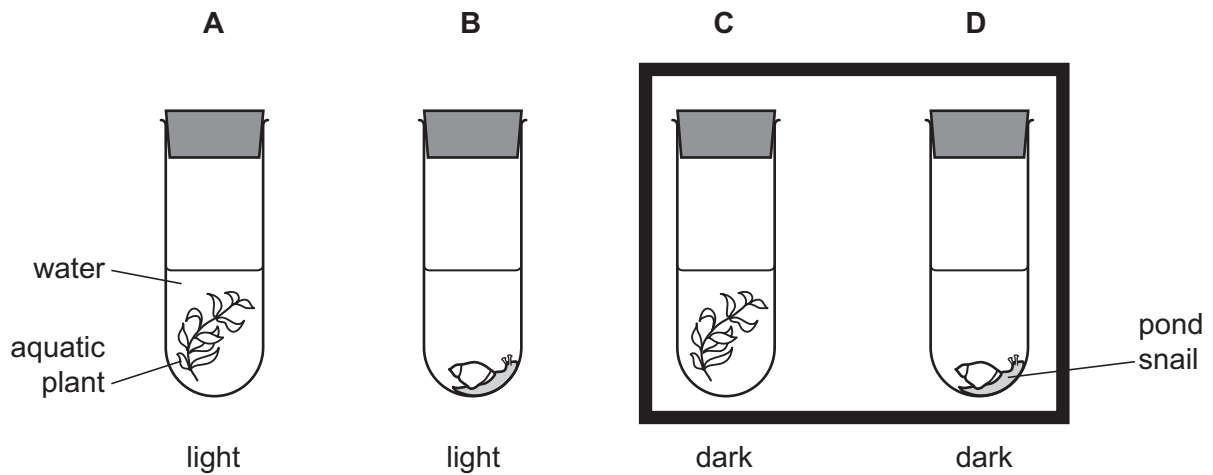

6 The diagram shows the human digestive system.

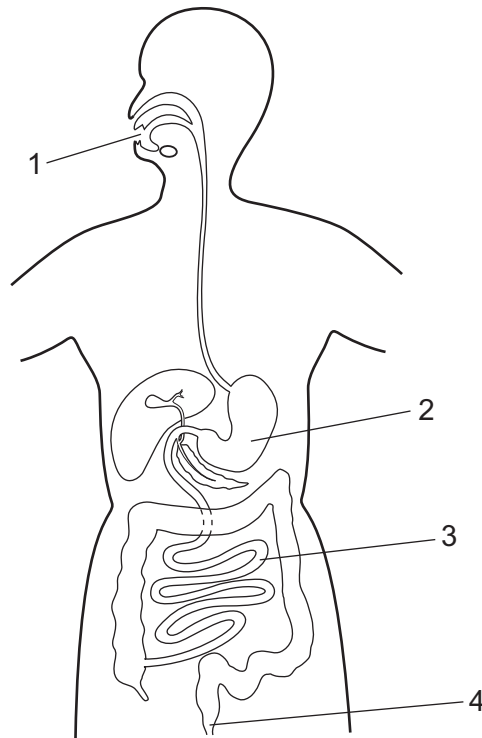

Where do digestion, egestion, ingestion and absorption take place?

	digestion	egestion	ingestion	absorption
A	1	4	2	3
B	2	4	1	3
C	3	1	4	2
D	4	3	2	1

7 Transpiration is the process by which water moves through a plant.

From which cells in the leaf does most of the water evaporate and through which structure is it lost as water vapour to the atmosphere?

	evaporates from	lost as water vapour through
A	epidermis	cuticle
B	epidermis	stomata
C	mesophyll	cuticle
D	mesophyll	stomata

- 8 A child blows into a rubber balloon.

What is the percentage of oxygen inside the balloon?

- A 0% B 4% C 16% D 21%

- 9 A student is in a dangerous situation and adrenaline is released into the blood. The table shows changes to pulse rate, breathing rate and pupil diameter.

Which row correctly describes the effect of adrenaline?

	pulse rate	breathing rate	pupil diameter
A	decrease	increase	decrease
B	decrease	decrease	increase
C	increase	increase	increase
D	increase	decrease	decrease

- 10 The diagram shows the human male reproductive system.

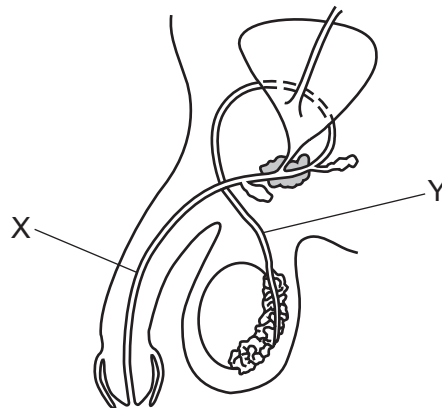

What are the functions of X and Y?

	X	Y
A	carries urine and semen out of the body	transfers sperm to the urethra
B	production of male gametes	transfers semen to the vagina during sexual intercourse
C	transfers semen to the vagina during sexual intercourse	production of male gametes
D	transfers sperm to the urethra	carries urine and semen out of the body

11 Which row is correct for the inheritance of sex in humans?

	female	male
A	XX	XY
B	XY	XX
C	YY	XX
D	XX	YY

12 Dung beetles lay their eggs in the faeces of plant-eating mammals like buffalo. Both the adult beetles and their young stages eat the **undigested** food in the faeces.

Which diagram shows this food relationship?

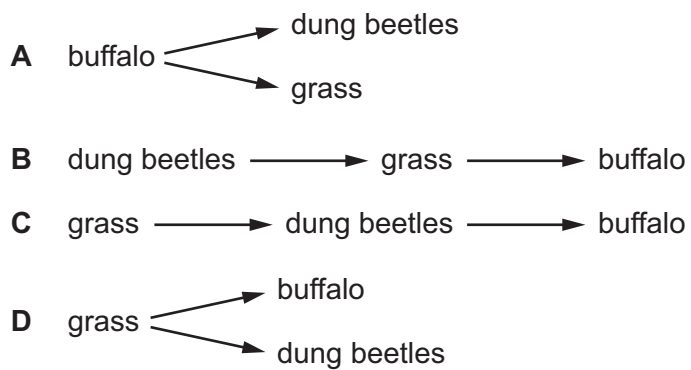

13 Which process removes carbon dioxide from the atmosphere?

- A** combustion
- B** photosynthesis
- C** respiration
- D** transpiration

14 The structures of some substances are shown.

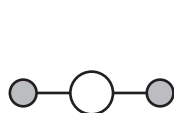

water

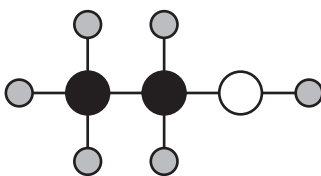

ethanol

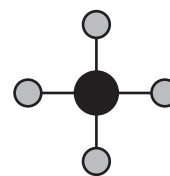

methane

Which row shows the total number of different elements and the total number of atoms in the three structures?

	total number of different elements	total number of atoms
A	3	9
B	3	17
C	7	9
D	7	17

15 Which method can be used to separate graphite from dilute nitric acid?

- A** chromatography
- B** crystallisation
- C** distillation
- D** filtration

16 Which statement about a carbon dioxide molecule is correct?

- A** It is composed of metallic elements, which are covalently bonded.
- B** It is composed of metallic elements, which are ionically bonded.
- C** It is composed of non-metallic elements, which are covalently bonded.
- D** It is composed of non-metallic elements, which are ionically bonded.

- 17 Hydrogen reacts with iodine to form hydrogen iodide.

The equation for this reaction is shown.

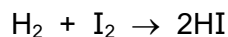

During this reaction the temperature increases.

Which statement explains why the temperature increases?

- A One molecule of hydrogen is forming two molecules of hydrogen iodide.
 - B The reaction is exothermic.
 - C The reaction is very fast.
 - D The reaction takes in energy.
- 18 The catalytic converter in the exhaust of a car brings about the reaction shown.

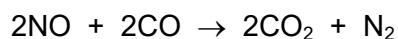

Which row about this reaction is correct?

	oxidation	reduction	
A	✓	✓	key
B	✓	x	✓ = occurs
C	x	✓	x = does not occur
D	x	x	

- 19 The results of two tests on substance X are listed.

- 1 A lilac flame is produced in a flame test.
- 2 A gas which turns damp red litmus blue is produced when X is heated with aluminium powder and aqueous sodium hydroxide.

What is X?

- A potassium nitrate
- B potassium sulfate
- C sodium nitrate
- D sodium sulfate

20 What reacts with ammonia gas?

	hydrochloric acid	sodium hydroxide	
A	✓	✓	key ✓ = reacts x = does not react
B	✓	x	
C	x	✓	
D	x	x	

21 Which row describes trends in the properties of Group I elements as the group is descended?

	melting point	reactivity with water
A	decreasing	decreasing
B	decreasing	increasing
C	increasing	decreasing
D	increasing	increasing

22 Bauxite is the main ore of aluminium.

Which method is used to extract pure aluminium from bauxite?

- A** fractional distillation
- B** electrolysis
- C** neutralisation
- D** thermal decomposition

23 In order to make water from reservoirs fit to drink1..... is used to kill bacteria.

Water in a condenser is used during distillation as a2..... .

When water is used to make ethanol from ethene it is acting as a3..... .

Which words correctly complete gaps 1, 2 and 3?

	1	2	3
A	chlorination	coolant	reactant
B	chlorination	solvent	solvent
C	filtration	coolant	reactant
D	filtration	solvent	solvent

24 Other than hydrogen and oxygen, which substance provides only **one** of the essential elements for plant growth?

- A K_3PO_4 B KNO_3 C $(NH_4)_3PO_4$ D NH_4NO_3

25 What are the products of the thermal decomposition of calcium carbonate, $CaCO_3$?

- A calcium and carbon dioxide
 B calcium, carbon and oxygen
 C calcium oxide and carbon dioxide
 D calcium oxide and carbon monoxide

26 Which property allows petroleum to be separated by fractional distillation?

- A boiling point
 B colour
 C density
 D melting point

27 Poly(ethene) is a saturated hydrocarbon.

It is formed by the addition polymerisation of ethene, $H_2C=CH_2$.

Which diagram shows part of a molecule of poly(ethene)?

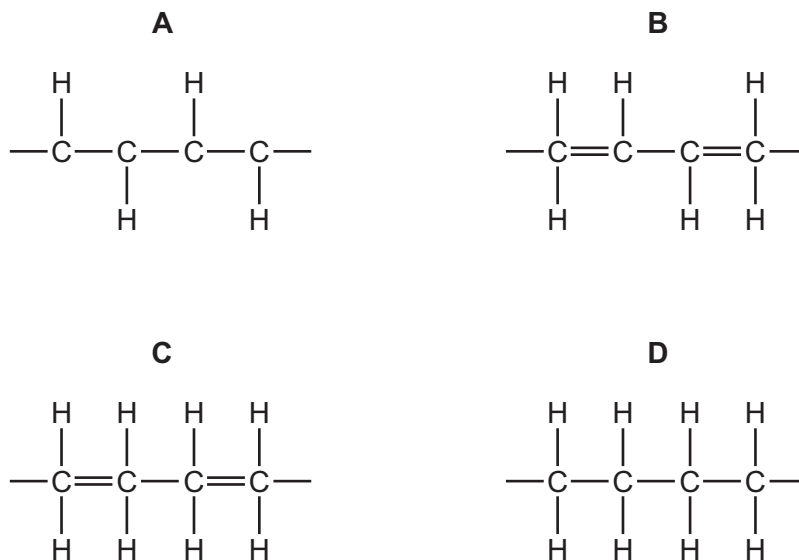

28 A girl runs 5000 m in 1200 seconds and then walks a further 3000 m in 1800 seconds.

What is her average speed for this journey?

- A 1.7 m/s B 2.7 m/s C 2.9 m/s D 5.8 m/s

29 An object is falling freely near the Earth without air resistance.

Which statement about the acceleration of the object is correct?

- A It is constant, but not zero.
- B It is decreasing.
- C It is increasing.
- D It is zero.

30 Three objects X, Y and Z are at rest on a table. The centre of mass of each object is labelled M.

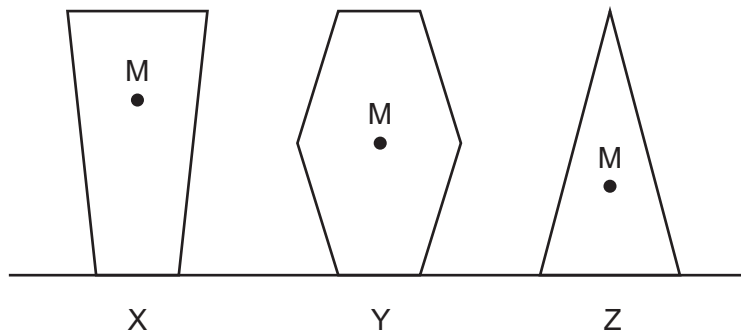

What is the order of stability of these three objects, from most stable to least stable?

- A $X \rightarrow Y \rightarrow Z$
- B $Y \rightarrow Z \rightarrow X$
- C $X \rightarrow Z \rightarrow Y$
- D $Z \rightarrow Y \rightarrow X$

31 The diagram shows a man diving into water.

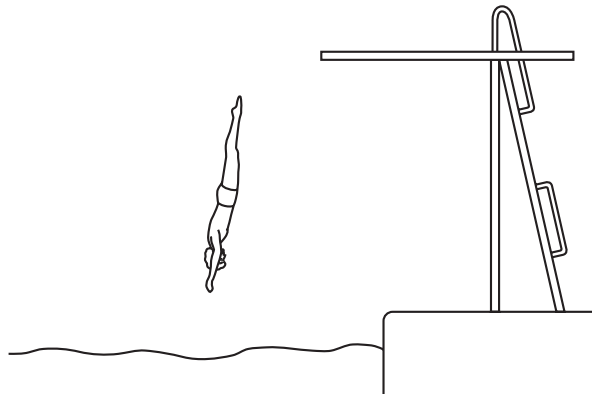

Which form of energy is increasing as he accelerates downwards through the air?

- A chemical
- B elastic potential (strain)
- C gravitational potential
- D kinetic

32 There is a vacuum between the double walls of a vacuum flask.

Which of the methods of thermal energy transfer are prevented by the vacuum?

- A conduction only
- B conduction and convection
- C convection only
- D radiation only

33 A boy looks into a plane mirror that is 50 cm in front of his face.

How far from the boy's face is the image of his face?

- A 25 cm B 50 cm C 100 cm D 150 cm

34 The diagram shows the image of an object produced by a thin converging lens.

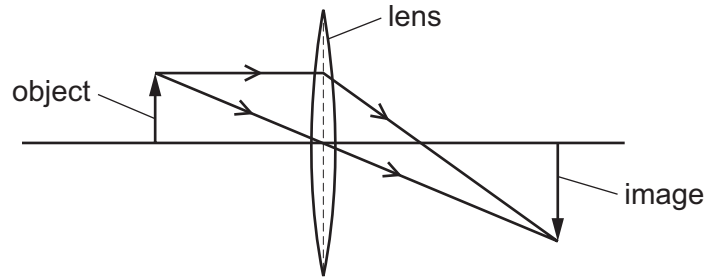

How is the image described?

- A diminished and inverted
- B diminished and upright
- C enlarged and inverted
- D enlarged and upright

- 35 Sound from a loudspeaker at P travels directly to Q. Sound also reaches Q after being reflected from a wall at R.

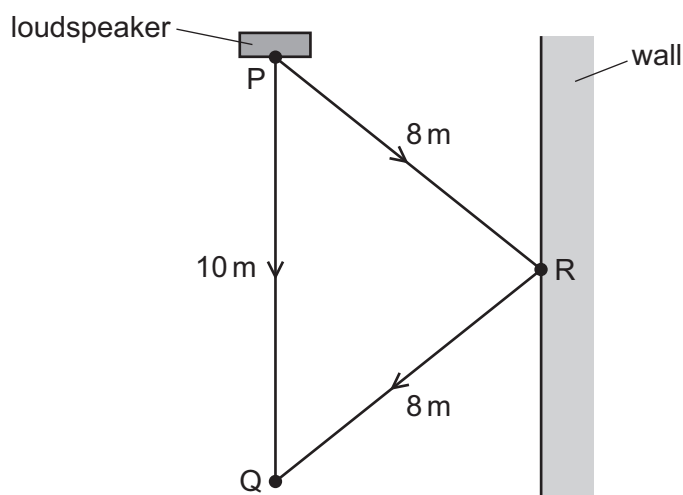

The speed of sound is 330 m/s.

What is the **difference** in time for sound to travel from P to Q by the two routes?

- A $\left(\frac{6}{330}\right)$ s B $\left(\frac{16}{330}\right)$ s C (6×330) s D (16×330) s

- 36 Which circuit can be used to take measurements to determine the resistance of resistor R?

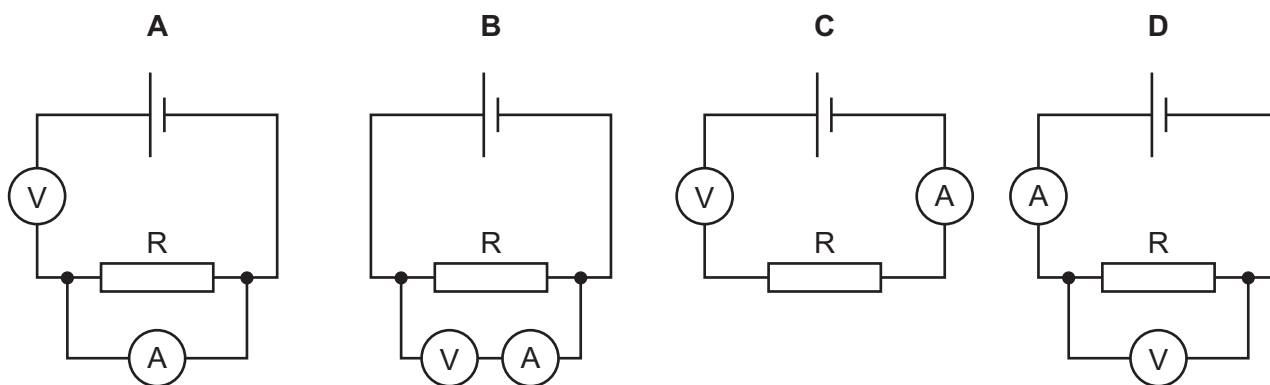

- 37 In which circuit can the brightness of the lamp be varied continuously?

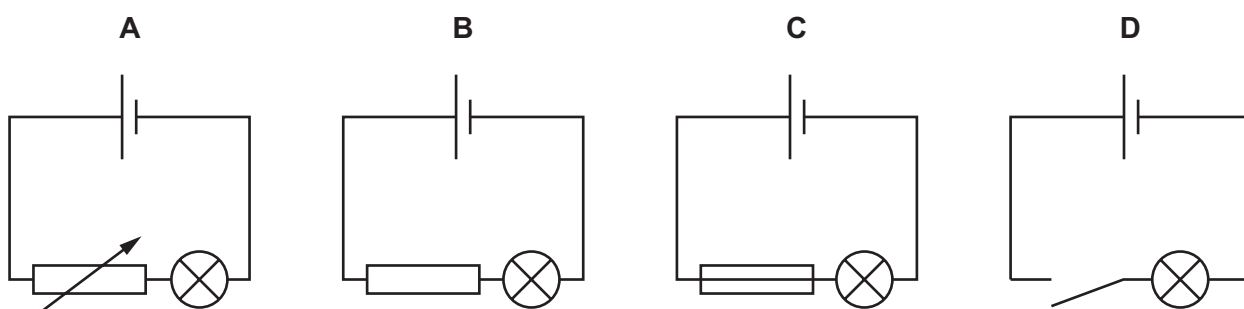

38 A student connects the circuit shown.

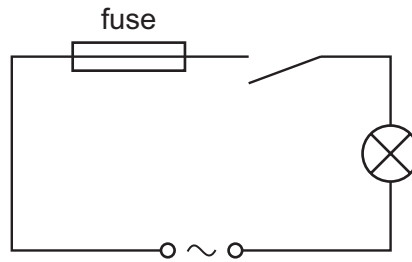

When the switch is closed the fuse blows and stops the current.

What is a possible reason for this?

- A The current rating of the fuse is too high.
 - B The current is too large.
 - C The lamp is too dim.
 - D The voltage is too small.
- 39 The diagram shows a wire in a magnetic field.

There is a current in the wire.

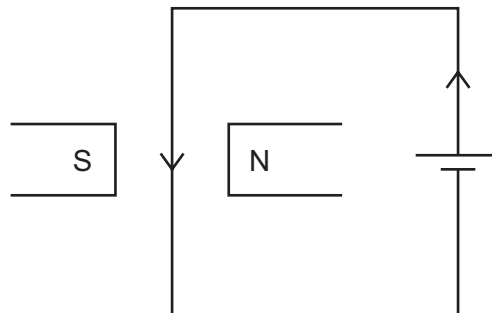

The force produced on the wire causes the wire to move into the page.

The direction of the current is now reversed.

What happens to the wire?

- A It does not move at all.
- B It moves out of the page.
- C It moves sideways towards one of the poles of the magnet.
- D It still moves into the page.

40 A radioactive nucleus emits a β -particle.

What happens to the proton number (atomic number) of the nucleus?

- A It stays the same.
- B It increases by 1.
- C It decreases by 2.
- D It decreases by 4.

Permission to reproduce items where third-party owned material protected by copyright is included has been sought and cleared where possible. Every reasonable effort has been made by the publisher (UCLES) to trace copyright holders, but if any items requiring clearance have unwittingly been included, the publisher will be pleased to make amends at the earliest possible opportunity.

To avoid the issue of disclosure of answer-related information to candidates, all copyright acknowledgements are reproduced online in the Cambridge Assessment International Education Copyright Acknowledgements Booklet. This is produced for each series of examinations and is freely available to download at www.cambridgeinternational.org after the live examination series.

Cambridge Assessment International Education is part of the Cambridge Assessment Group. Cambridge Assessment is the brand name of the University of Cambridge Local Examinations Syndicate (UCLES), which itself is a department of the University of Cambridge.

The Periodic Table of Elements

Group																						
I	II	III						IV	V	VI	VII	VIII										
3 Li lithium 7	4 Be beryllium 9	<div style="border: 1px solid black; padding: 5px; text-align: center;"> Key atomic number atomic symbol name relative atomic mass </div>										2 He helium 4										
11 Na sodium 23	12 Mg magnesium 24											5 B boron 11	6 C carbon 12	7 N nitrogen 14	8 O oxygen 16	9 F fluorine 19	10 Ne neon 20					
19 K potassium 39	20 Ca calcium 40	13 Al aluminium 27	14 Si silicon 28	15 P phosphorus 31	16 S sulfur 32	17 Cl chlorine 35.5	18 Ar argon 40	33 As arsenic 75	34 Se selenium 79	35 Br bromine 80	36 Kr krypton 84											
37 Rb rubidium 85	38 Sr strontium 88	31 Ga gallium 70	32 Ge germanium 73	33 As arsenic 75	34 Se selenium 79	35 Br bromine 80	36 Kr krypton 84	47 Ag silver 108	48 Cd cadmium 112	49 In indium 115	50 Sn tin 119	51 Sb antimony 122	52 Te tellurium 128	53 I iodine 127	54 Xe xenon 131							
55 Cs caesium 133	56 Ba barium 137	26 Fe iron 56	27 Co cobalt 59	28 Ni nickel 59	29 Cu copper 64	30 Zn zinc 65	31 Ga gallium 70	76 Os osmium 190	77 Ir iridium 192	78 Pt platinum 195	79 Au gold 197	80 Hg mercury 201	81 Tl thallium 204	82 Pb lead 207	83 Bi bismuth 209	84 Po polonium —	85 At astatine —	86 Rn radon —				
87 Fr francium —	88 Ra radium —	25 Mn manganese 55	26 Fe iron 56	27 Co cobalt 59	28 Ni nickel 59	29 Cu copper 64	30 Zn zinc 65	75 Re rhenium 186	76 Os osmium 190	77 Ir iridium 192	78 Pt platinum 195	79 Au gold 197	80 Hg mercury 201	81 Tl thallium 204	82 Pb lead 207	83 Bi bismuth 209	84 Po polonium —	85 At astatine —	86 Rn radon —			
89–103 actinoids	—	24 Cr chromium 52	25 Mn manganese 55	26 Fe iron 56	27 Co cobalt 59	28 Ni nickel 59	29 Cu copper 64	30 Zn zinc 65	74 W tungsten 184	75 Re rhenium 186	76 Os osmium 190	77 Ir iridium 192	78 Pt platinum 195	79 Au gold 197	80 Hg mercury 201	81 Tl thallium 204	82 Pb lead 207	83 Bi bismuth 209	84 Po polonium —	85 At astatine —	86 Rn radon —	
—	—	23 V vanadium 51	24 Cr chromium 52	25 Mn manganese 55	26 Fe iron 56	27 Co cobalt 59	28 Ni nickel 59	29 Cu copper 64	30 Zn zinc 65	107 Bh bohrium —	108 Hs hassium —	109 Mt meitnerium —	110 Ds darmstadtium —	111 Rg roentgenium —	112 Cn copernicium —	114 Fl flerovium —	116 Lv livermorium —	—	—	—	—	—

lanthanoids	57 La lanthanum 139	58 Ce cerium 140	59 Pr praseodymium 141	60 Nd neodymium 144	61 Pm promethium —	62 Sm samarium 150	63 Eu europium 152	64 Gd gadolinium 157	65 Tb terbium 159	66 Dy dysprosium 163	67 Ho holmium 165	68 Er erbium 167	69 Tm thulium 169	70 Yb ytterbium 173	71 Lu lutetium 175
actinoids	89 Ac actinium —	90 Th thorium 232	91 Pa protactinium 231	92 U uranium 238	93 Np neptunium —	94 Pu plutonium —	95 Am americium —	96 Cm curium —	97 Bk berkelium —	98 Cf californium —	99 Es einsteinium —	100 Fm fermium —	101 Md mendelevium —	102 No nobelium —	103 Lr lawrencium —

The volume of one mole of any gas is 24 dm³ at room temperature and pressure (r.t.p.).