



# Cambridge IGCSE™

CANDIDATE  
NAME

--

CENTRE  
NUMBER

--	--	--	--	--

CANDIDATE  
NUMBER

--	--	--	--



**COMBINED SCIENCE**

**0653/42**

Paper 4 Theory (Extended)

**May/June 2020**

**1 hour 15 minutes**

You must answer on the question paper.

No additional materials are needed.

## INSTRUCTIONS

- Answer **all** questions.
- Use a black or dark blue pen. You may use an HB pencil for any diagrams or graphs.
- Write your name, centre number and candidate number in the boxes at the top of the page.
- Write your answer to each question in the space provided.
- Do **not** use an erasable pen or correction fluid.
- Do **not** write on any bar codes.
- You may use a calculator.
- You should show all your working and use appropriate units.

## INFORMATION

- The total mark for this paper is 80.
- The number of marks for each question or part question is shown in brackets [ ].
- The Periodic Table is printed in the question paper.

This document has **20** pages. Blank pages are indicated.

1 (a) Fig. 1.1 represents a plant cell.

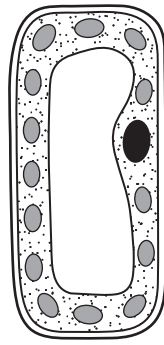

Fig. 1.1

Add labels to Fig. 1.1 to name **two** structures that are **only** present in plant cells. [2]

(b) Fig. 1.2 represents an animal cell from the trachea.



Fig. 1.2

Describe how the structure of this cell is adapted to its function.

.....

.....

..... [2]

(c) Fig. 1.3 shows part of a food web.

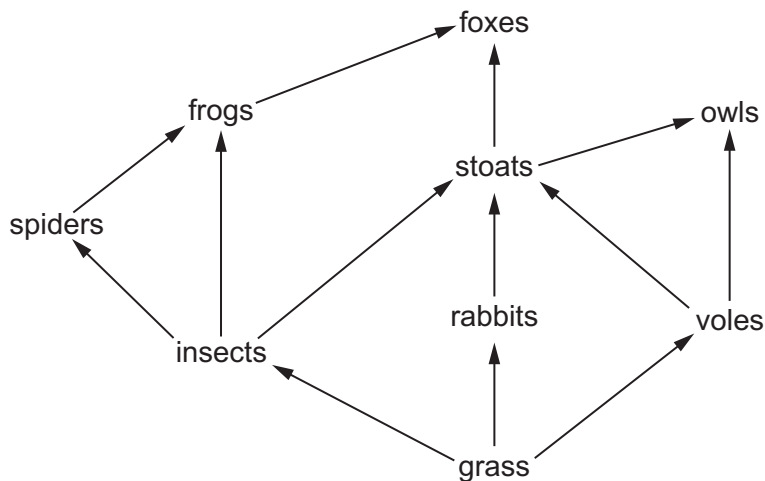

Fig. 1.3

(i) Define the term *consumer*.

.....  
..... [1]

(ii) List **all** of the tertiary consumers shown in the food web in Fig. 1.3.

Explain how you identified these consumers using the term *trophic level*.

tertiary consumers .....

.....

explanation .....

..... [2]

(iii) Complete the food chain containing five organisms from the food web in Fig. 1.3.



[1]

(iv) Describe what the arrows in the food chain represent.

..... [1]

(d) Use words from the list to complete the sentences about photosynthesis.

- chemical      chlorophyll      cytoplasm      glucose
- light      oxygen      starch      thermal

Each word may be used once, more than once or not at all.

During photosynthesis ..... energy is transferred into  
..... energy by ..... molecules. [2]

[Total: 11]

2 The fractional distillation of petroleum is shown in Fig. 2.1.

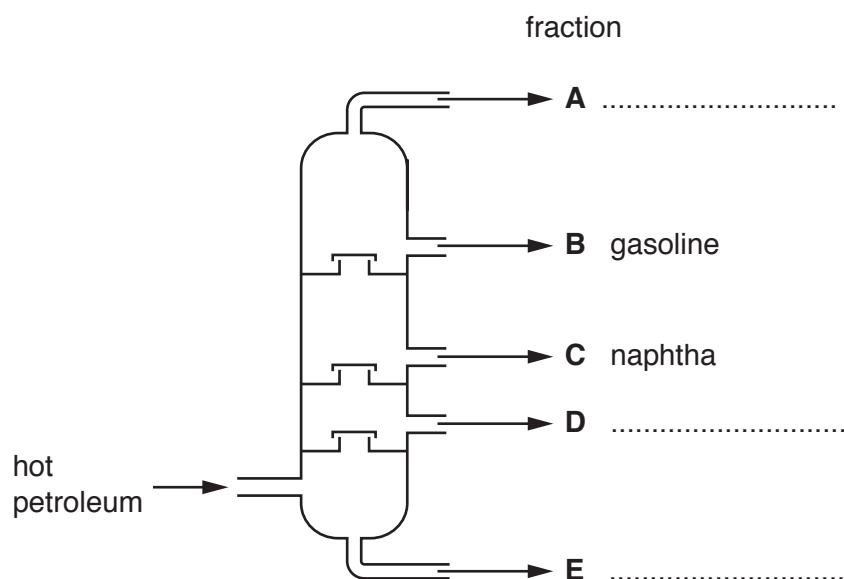

Fig. 2.1

(a) **A, B, C, D** and **E** are five fractions.

The names of these five fractions are bitumen, diesel oil, gasoline, naphtha and refinery gas.

(i) Identify these fractions by completing Fig. 2.1. Two have been done for you. [1]

(ii) Fraction **A** is a mixture of compounds. They are all hydrocarbons.

Describe **two** other ways in which the compounds in fraction **A** are similar.

1. ....

2. ....

[2]

(iii) State **one** use for naphtha.

..... [1]

(b) Methane,  $\text{CH}_4$ , and pentane,  $\text{C}_5\text{H}_{12}$ , are members of the homologous series of alkanes.

(i) State what is meant by a *homologous series*.

.....

.....

.....

..... [2]

- (ii) Write the balanced symbol equation for the complete combustion of pentane,  $C_5H_{12}$ , in oxygen.

..... [2]

[Total: 8]

- 3 Fig. 3.1 shows a sheet of metal on the sea floor. The dotted lines show the column of sea water vertically above the sheet which exerts a pressure on the metal sheet.

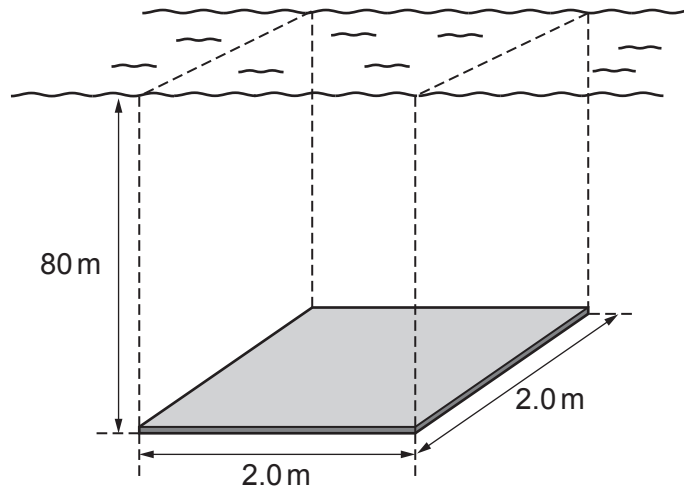

**Fig. 3.1** (not to scale)

The surface of the sheet measures  $2.0\text{ m} \times 2.0\text{ m}$ . The sheet is  $80\text{ m}$  below the sea surface.

- (a) (i) Calculate the volume of the column of sea water vertically above the sheet.

volume = .....  $\text{m}^3$  [1]

- (ii) The density of sea water is  $1030\text{ kg/m}^3$ .

The Earth's gravitational field strength is  $10\text{ N/kg}$ .

Show that the weight of the column of sea water on top of the sheet is  $3.30 \times 10^6\text{ N}$ .

[3]

- (iii) Calculate the pressure of this column of sea water on the metal sheet.

Give the unit.

pressure = ..... unit ..... [3]

(b) Fig. 3.2 shows a crane lifting the metal sheet off the sea floor.

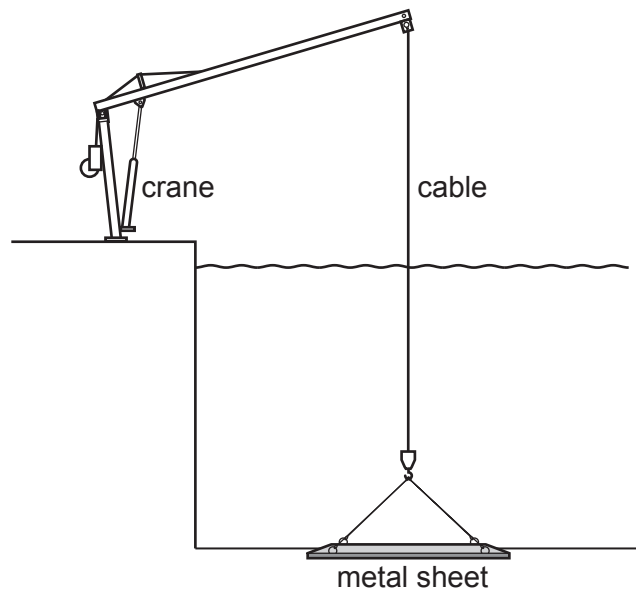

**Fig. 3.2** (not to scale)

The cable stretches according to Hooke's Law as the lifting force increases.

On Fig. 3.3, sketch the graph of the extension of the cable as the force increases.

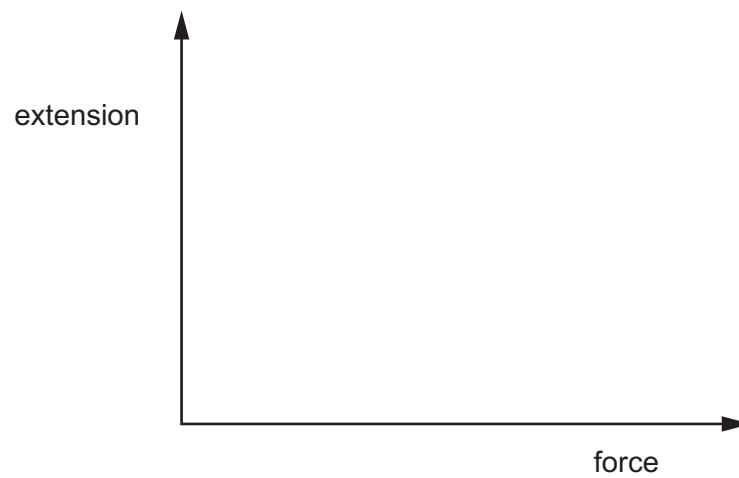

**Fig. 3.3**

[1]

[Total: 8]

- 4 (a) Fig. 4.1 shows two similar stalks of celery, **X** and **Y**. They are placed in water containing a red stain. **X** and **Y** are left in environments of different humidity for 15 minutes.

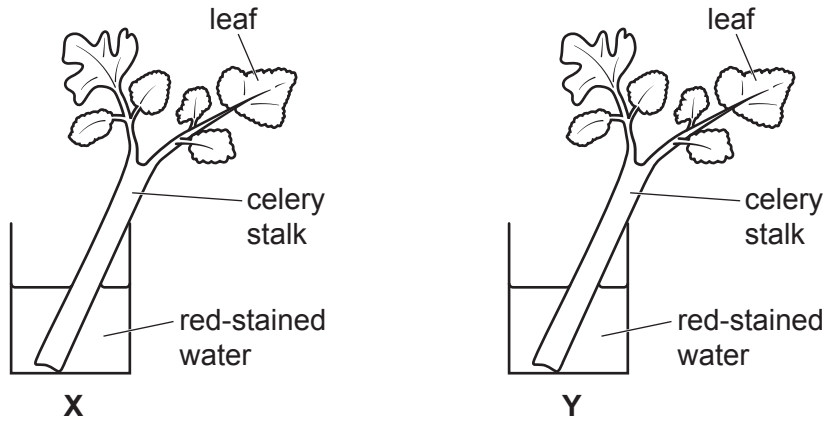

Fig. 4.1

The distance the red-stained water travels in each stalk is measured. The results are shown in Table 4.1.

Table 4.1

stalk	distance moved upwards by the red stain/mm
<b>X</b>	45
<b>Y</b>	72

- (i) Calculate the difference in distance moved by the red-stained water in stalk **X** and in stalk **Y**.

difference in distance = ..... mm [1]

- (ii) Explain your answer to (a)(i) in terms of the humidity of the environments of **X** and **Y**.

.....  
 .....  
 .....  
 ..... [3]

- (b) Name the tissue which transports water upwards through the stalks of the celery.

..... [1]



(c) Plants get nitrate ions from water entering through their roots.

(i) Describe the importance of nitrate ions in the plant.

.....  
..... [1]

(ii) Describe the effect of nitrate ion deficiency in the plant.

..... [1]

[Total: 7]

- 5 The equation for the reaction between magnesium carbonate and dilute hydrochloric acid is shown.



- (a) The reaction between magnesium carbonate and dilute hydrochloric acid is exothermic.

The energy level diagram for this reaction is shown in Fig. 5.1.

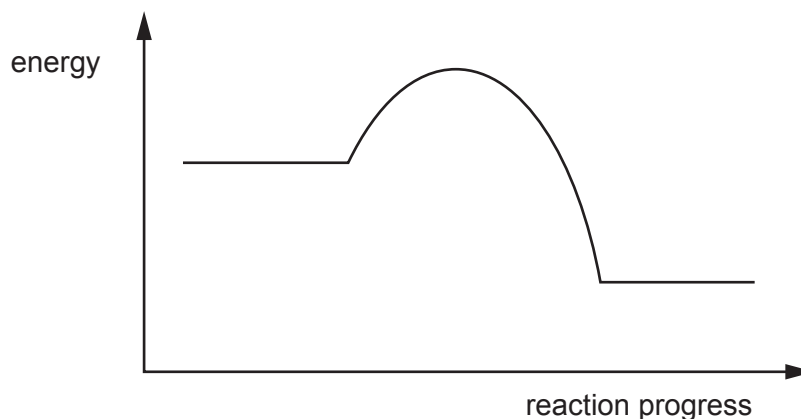

Fig. 5.1

- (i) On Fig. 5.1, write the words *reactants* and *products* in suitable places. [1]
- (ii) On Fig. 5.1, draw a double headed arrow ( $\rightleftharpoons$ ) to show the activation energy for this reaction. [1]
- (b) A student investigates the effect of temperature on the rate of reaction between magnesium carbonate and dilute hydrochloric acid.

She uses acid with a temperature of 20°C. She measures the volume of carbon dioxide produced.

- (i) Fig. 5.2 is a graph of her results.

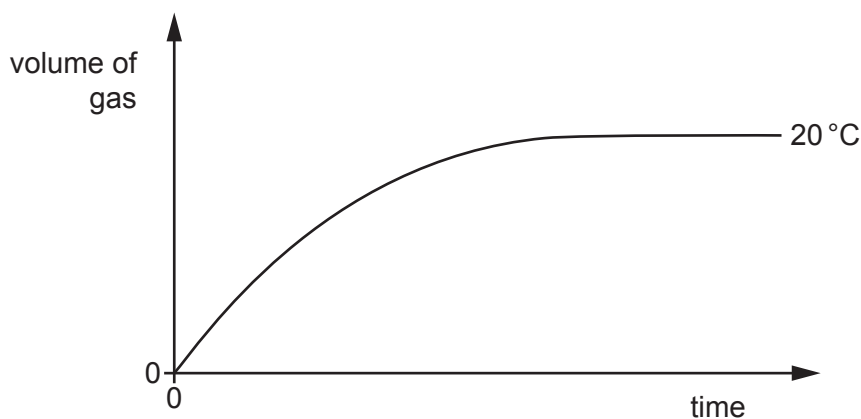

Fig. 5.2

On Fig. 5.2, sketch a graph of the results she obtains when she repeats the experiment at a temperature of 30°C. All other variables are kept constant. [2]

(ii) Explain your answer to (b)(i) using ideas about particle collisions.

.....  
.....  
..... [2]

(c) Carbon dioxide is one product of the reaction between magnesium carbonate and dilute hydrochloric acid.

Explain why scientists are concerned about an increase in the concentration of carbon dioxide in the atmosphere.

.....  
.....  
.....  
..... [2]

(d) Magnesium chloride is another product of the reaction between magnesium carbonate and dilute hydrochloric acid.

State **one** substance, other than magnesium carbonate, that reacts with dilute hydrochloric acid to produce magnesium chloride.

..... [1]

[Total: 9]

- 6 Fig. 6.1 shows a man's hand holding a metal rod in a hot flame.

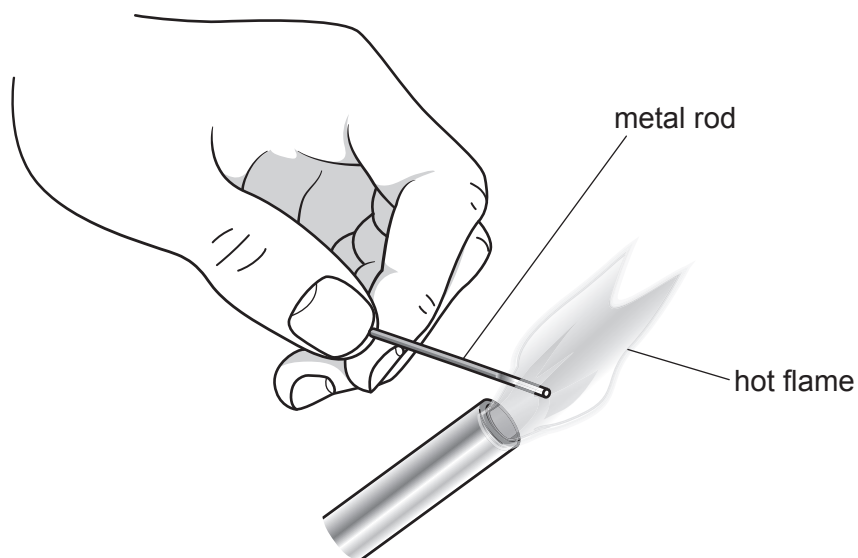

**Fig. 6.1**

- (a) After heating the metal rod in the flame for one minute, it glows red. The man suddenly drops the rod as the end he holds becomes too hot to hold.

- (i) Describe how the metal atoms transfer the thermal energy from the flame to the man's hand.

.....

.....

.....

..... [2]

- (ii) Suggest why the metal rod took as long as one minute to become too hot to hold.

.....

..... [1]

(b) (i) When heated, the metal rod glows red, then yellow as it gets hotter.

When the rod is removed from the flame, the yellow colour changes to red, and as it cools further, visible light is no longer emitted.

The man can still feel thermal energy radiating from the cooling rod.

State the type of electromagnetic radiation coming from the rod at this stage of cooling.

..... [1]

(ii) The metal rod is a shiny silver colour before it is heated.

After heating, the rod is covered with a dull black layer of the oxide of the metal.

State the effect this change will have on the rate of cooling of the rod.

Explain your answer.

.....  
.....  
..... [2]

(c) An astronomer using a telescope sees red light reflected from the planet Mars.

The astronomer knows that Mars at this time is 60 000 000 km from Earth.

(i) State the speed at which the red light travels from Mars to Earth.

..... [1]

(ii) Calculate the time taken for the red light to travel from Mars to Earth.

time = ..... s [2]

[Total: 9]

- 7 (a) Fig. 7.1 shows a diagram of the internal structure of the heart and the blood vessels to and from the heart.

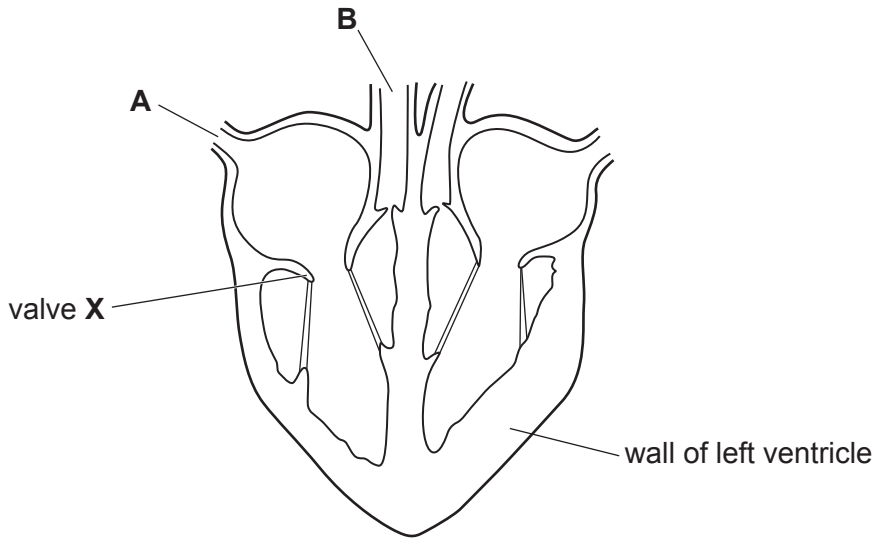

Fig. 7.1

- (i) On Fig. 7.1, label the septum of the heart. [1]
- (ii) Describe the action of the atrium, ventricle and valve X to cause blood to flow from vessel A to vessel B.

.....

.....

.....

.....

.....

..... [4]

- (b) The coronary arteries provide blood to the heart muscle.

- (i) Suggest how a blockage of the coronary arteries affects heart function.
- .....
- .....
- ..... [2]

- (ii) State **two** factors which increase a person's chance of developing coronary heart disease.

1. ....

2. ....

[2]

[Total: 9]

8 (a) Copper is a transition metal.

State **two** properties of copper that are **not** properties of Group I metals.

- 1. ....
  - 2. ....
- [2]

(b) Zinc is extracted from zinc oxide, ZnO.

(i) The formula of an oxide ion is O<sup>2-</sup>.

Deduce the charge of a zinc ion.

Explain your answer.

charge .....

explanation .....

[2]

(ii) Explain why zinc can be extracted from zinc oxide by reduction with carbon.

Use ideas about the reactivity series in your answer.

.....

..... [1]

(c) Molten sodium chloride can be electrolysed.

(i) Explain why energy is needed to melt sodium chloride.

.....

..... [1]

(ii) Explain why sodium chloride must be molten, and **not** solid, during electrolysis.

.....

..... [1]

(iii) Predict the products of this electrolysis at the anode and at the cathode.

anode .....

cathode .....

[2]

[Total: 9]

9 Fig. 9.1 shows two circuits.

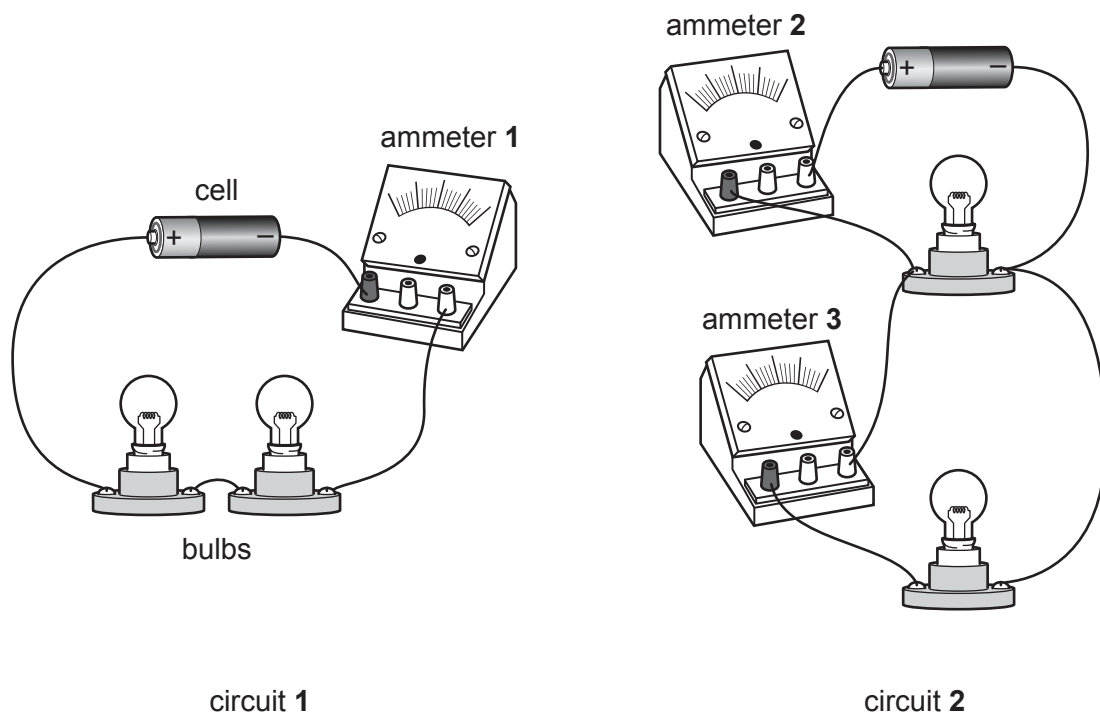

**Fig. 9.1**

In circuit 1 the bulbs are connected in series.

In circuit 2 the bulbs are connected in parallel.

The cells, the ammeters and all the bulbs are identical in both circuits.

- (a) Complete the circuit diagram for circuit 2 shown in Fig. 9.1. Include in your circuit diagram a switch that will turn off one bulb, but leave the other lit.

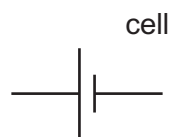

[3]



(b) State which of the three ammeters in Fig. 9.1 shows the highest reading.

Give reasons for your answer.

ammeter .....

.....  
 .....  
 ..... [2]

(c) Circuit 1 is switched on.

Ammeter 1 shows a current of 2.0A.

A voltmeter connected across the cell in circuit 1 gives a reading of 1.4V.

(i) State the potential difference (p.d.) across **one** of the lamps in circuit 1.

potential difference = ..... V [1]

(ii) Calculate the total energy supplied by the cell in circuit 1 in 300 seconds.

energy = ..... J [2]

(d) The resistance of each bulb in circuit 2 when lit is  $0.70\ \Omega$ .

Calculate the combined resistance of the two bulbs.

resistance = .....  $\Omega$  [2]

[Total: 10]



**BLANK PAGE**

---

Permission to reproduce items where third-party owned material protected by copyright is included has been sought and cleared where possible. Every reasonable effort has been made by the publisher (UCLES) to trace copyright holders, but if any items requiring clearance have unwittingly been included, the publisher will be pleased to make amends at the earliest possible opportunity.

To avoid the issue of disclosure of answer-related information to candidates, all copyright acknowledgements are reproduced online in the Cambridge Assessment International Education Copyright Acknowledgements Booklet. This is produced for each series of examinations and is freely available to download at [www.cambridgeinternational.org](http://www.cambridgeinternational.org) after the live examination series.

Cambridge Assessment International Education is part of the Cambridge Assessment Group. Cambridge Assessment is the brand name of the University of Cambridge Local Examinations Syndicate (UCLES), which itself is a department of the University of Cambridge.

