



## Cambridge International AS & A Level

CANDIDATE  
NAME

--

CENTRE  
NUMBER

--	--	--	--	--

CANDIDATE  
NUMBER

--	--	--	--



**PHYSICS**

**9702/42**

Paper 4 A Level Structured Questions

**October/November 2020**

**2 hours**

You must answer on the question paper.

No additional materials are needed.

### INSTRUCTIONS

- Answer **all** questions.
- Use a black or dark blue pen. You may use an HB pencil for any diagrams or graphs.
- Write your name, centre number and candidate number in the boxes at the top of the page.
- Write your answer to each question in the space provided.
- Do **not** use an erasable pen or correction fluid.
- Do **not** write on any bar codes.
- You may use a calculator.
- You should show all your working and use appropriate units.

### INFORMATION

- The total mark for this paper is 100.
- The number of marks for each question or part question is shown in brackets [ ].

This document has **24** pages. Blank pages are indicated.

**Data**

speed of light in free space	$c = 3.00 \times 10^8 \text{ m s}^{-1}$
permeability of free space	$\mu_0 = 4\pi \times 10^{-7} \text{ H m}^{-1}$
permittivity of free space	$\epsilon_0 = 8.85 \times 10^{-12} \text{ F m}^{-1}$
	$(\frac{1}{4\pi\epsilon_0} = 8.99 \times 10^9 \text{ m F}^{-1})$
elementary charge	$e = 1.60 \times 10^{-19} \text{ C}$
the Planck constant	$h = 6.63 \times 10^{-34} \text{ J s}$
unified atomic mass unit	$1 \text{ u} = 1.66 \times 10^{-27} \text{ kg}$
rest mass of electron	$m_e = 9.11 \times 10^{-31} \text{ kg}$
rest mass of proton	$m_p = 1.67 \times 10^{-27} \text{ kg}$
molar gas constant	$R = 8.31 \text{ J K}^{-1} \text{ mol}^{-1}$
the Avogadro constant	$N_A = 6.02 \times 10^{23} \text{ mol}^{-1}$
the Boltzmann constant	$k = 1.38 \times 10^{-23} \text{ J K}^{-1}$
gravitational constant	$G = 6.67 \times 10^{-11} \text{ N m}^2 \text{ kg}^{-2}$
acceleration of free fall	$g = 9.81 \text{ m s}^{-2}$

## Formulae

uniformly accelerated motion	$s = ut + \frac{1}{2}at^2$ $v^2 = u^2 + 2as$
work done on/by a gas	$W = p\Delta V$
gravitational potential	$\phi = -\frac{Gm}{r}$
hydrostatic pressure	$p = \rho gh$
pressure of an ideal gas	$p = \frac{1}{3}\frac{Nm}{V}\langle c^2 \rangle$
simple harmonic motion	$a = -\omega^2 x$
velocity of particle in s.h.m.	$v = v_0 \cos \omega t$ $v = \pm \omega \sqrt{(x_0^2 - x^2)}$
Doppler effect	$f_o = \frac{f_s v}{v \pm v_s}$
electric potential	$V = \frac{Q}{4\pi\epsilon_0 r}$
capacitors in series	$1/C = 1/C_1 + 1/C_2 + \dots$
capacitors in parallel	$C = C_1 + C_2 + \dots$
energy of charged capacitor	$W = \frac{1}{2}QV$
electric current	$I = Anvq$
resistors in series	$R = R_1 + R_2 + \dots$
resistors in parallel	$1/R = 1/R_1 + 1/R_2 + \dots$
Hall voltage	$V_H = \frac{BI}{ntq}$
alternating current/voltage	$x = x_0 \sin \omega t$
radioactive decay	$x = x_0 \exp(-\lambda t)$
decay constant	$\lambda = \frac{0.693}{t_{\frac{1}{2}}}$

Answer **all** the questions in the spaces provided.

- 1 (a) Define *gravitational potential* at a point.

.....  
 .....  
 ..... [2]

- (b) The Earth may be considered to be a uniform sphere of radius  $6.4 \times 10^6$  m with its mass of  $6.0 \times 10^{24}$  kg concentrated at its centre.

A satellite of mass  $2.4 \times 10^3$  kg is launched from the Equator. It is placed in an equatorial orbit at a height of  $5.6 \times 10^6$  m above the Earth's surface.

- (i) Calculate the change  $\Delta E_p$  in gravitational potential energy of the satellite for its movement from the surface of the Earth to its position in the equatorial orbit.

$$\Delta E_p = \dots\dots\dots \text{ J [3]}$$

- (ii) Determine the speed of the satellite when in orbit.

$$\text{speed} = \dots\dots\dots \text{ ms}^{-1} [3]$$

- (c) Before the satellite in (b) is launched, its speed at the Equator due to the Earth's rotation is  $470\text{ m s}^{-1}$ .

Suggest why the energy required to launch the satellite depends on whether the satellite, in its orbit, is travelling from west to east or from east to west.

.....  
..... [1]

[Total: 9]

- 2 (a) State what is meant by the *internal energy* of a system.

.....  
 .....  
 ..... [2]

- (b) The atoms of an ideal gas occupy a container of volume  $2.30 \times 10^{-3} \text{ m}^3$  at pressure  $2.60 \times 10^5 \text{ Pa}$  and temperature  $180 \text{ K}$ , as illustrated in Fig. 2.1.

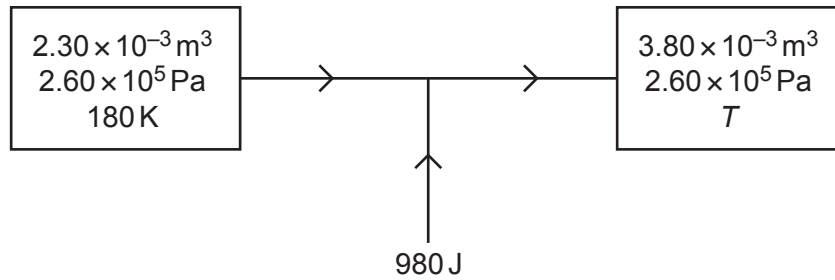

**Fig. 2.1**

The gas is heated at constant pressure so that its volume becomes  $3.80 \times 10^{-3} \text{ m}^3$  at a temperature  $T$ .

For the fixed mass of gas, calculate:

- (i) the amount of substance, in mol

amount = ..... mol [2]

- (ii) the temperature  $T$ , in K.

$T = \dots\dots\dots$  K [2]

(c) During the change in (b), the thermal energy supplied to the gas is 980 J.

(i) Determine the work done on the gas during this change. Explain your working.

work done = ..... J [3]

(ii) Determine the change  $\Delta U$  in internal energy of the gas.

$\Delta U = \dots\dots\dots$  J [1]

[Total: 10]

- 3 A simple pendulum consists of a metal sphere suspended from a fixed point by means of a thread, as illustrated in Fig. 3.1.

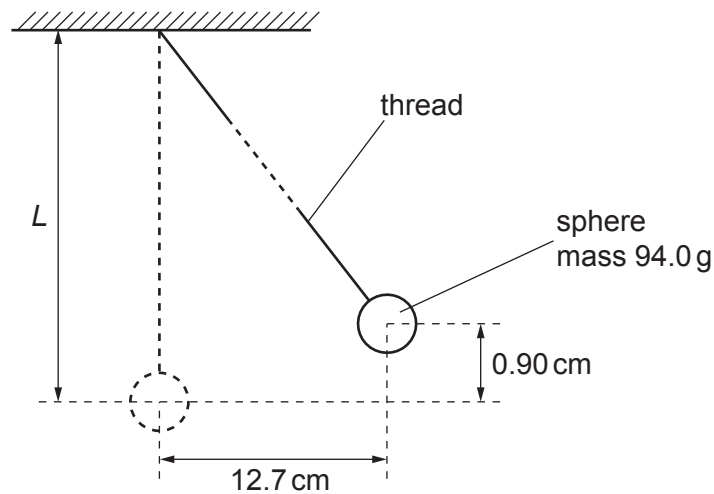

**Fig. 3.1** (not to scale)

The sphere of mass 94.0 g is displaced to one side through a horizontal distance of 12.7 cm. The centre of gravity of the sphere rises vertically by 0.90 cm.

The sphere is released so that it oscillates. The sphere may be assumed to oscillate with simple harmonic motion.

- (a) State what is meant by *simple harmonic motion*.

.....  
 .....  
 ..... [2]

- (b) (i) State the kinetic energy of the sphere when the sphere returns to the displaced position shown in Fig. 3.1.

kinetic energy = ..... J [1]

- (ii) Calculate the total energy  $E_T$  of the oscillations.

$E_T = \dots\dots\dots$  J [2]



- (iii) Use your answer in (ii) to show that the angular frequency  $\omega$  of the oscillations of the pendulum is  $3.3 \text{ rad s}^{-1}$ .

[2]

- (c) The period  $T$  of oscillation of the pendulum is given by the expression

$$T = 2\pi\sqrt{\left(\frac{L}{g}\right)}$$

where  $g$  is the acceleration of free fall and  $L$  is the length of the pendulum.

Use data from (b) to determine  $L$ .

$L = \dots\dots\dots \text{ m [3]}$

[Total: 10]

4 (a) State **two** advantages of the transmission of data in digital, rather than analogue, form.

1. ....
- .....
2. ....
- .....

[2]

(b) An analogue signal is to be transmitted in digital form.

The transmission system may be represented in block form as in Fig. 4.1.

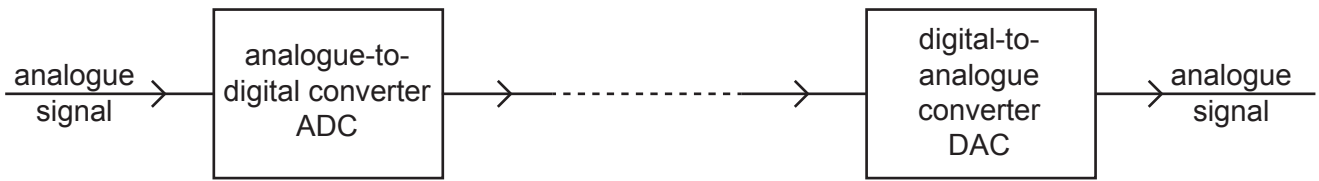

Fig. 4.1

The variation with time  $t$  of part of the input analogue signal is shown in Fig. 4.2.

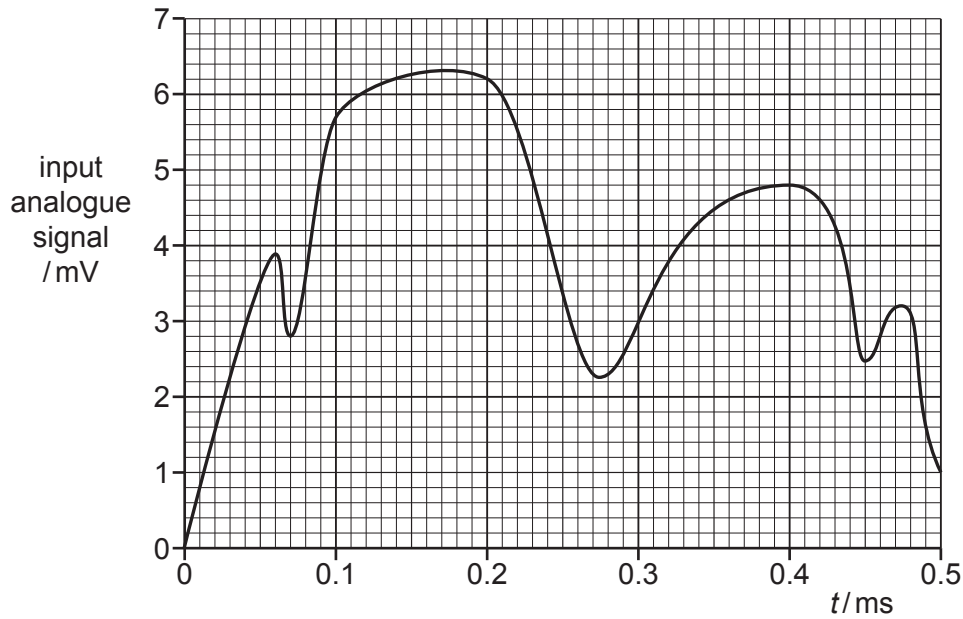

Fig. 4.2

The analogue signal is sampled at time intervals of 0.10 ms. The first sample is taken at time  $t = 0$ .

Some values of the sampled analogue signal and the corresponding digital signals are shown in Table 4.1.

Each digitised number contains four bits.

**Table 4.1**

time $t$ /ms	0	0.10	0.20	0.30	0.40	0.50
analogue signal /mV	0	5.7	6.2	.....	.....	.....
digital signal	0000	0101	0110	.....	.....	.....

- (i) In Table 4.1, underline the least significant bit (LSB) in the digital signal for the time of 0.20 ms. [1]
- (ii) Complete Table 4.1. [3]
- (c) A single bit from the output of the digital-to-analogue converter corresponds to an output analogue signal of 1.0 mV.

Assume that the conversion and transmission do not introduce a time delay.

On the axes of Fig. 4.3, show the variation with time  $t$  of the output from the digital-to-analogue converter.

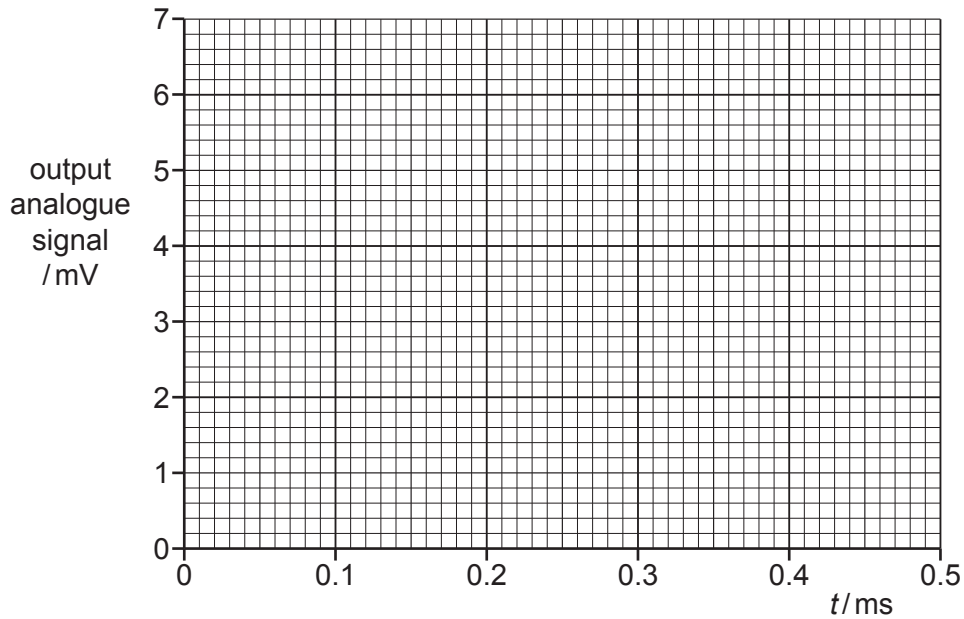

**Fig. 4.3**

[3]

[Total: 9]

5 (a) (i) State what is meant by a *field of force*.

.....  
 .....  
 ..... [2]

(ii) State **one** similarity and **one** difference between the electric field due to a point charge and the gravitational field due to a point mass.

similarity: .....  
 .....  
 .....  
 difference: .....  
 .....  
 ..... [2]

(b) An isolated solid metal sphere of radius 0.15m is situated in a vacuum, as illustrated in Fig. 5.1.

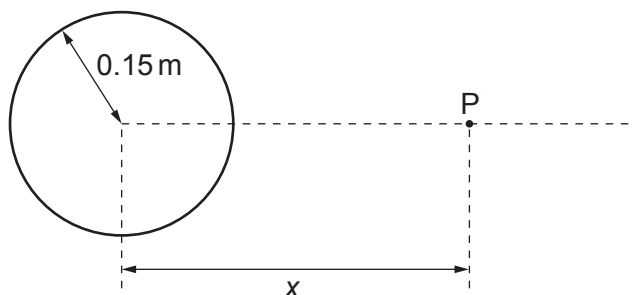

Fig. 5.1

The electric field strength at the surface of the sphere is  $84 \text{ V m}^{-1}$ .

Determine:

(i) the charge  $Q$  on the sphere

$Q = \dots\dots\dots \text{ C}$  [2]

- (ii) the electric field strength at point P, a distance  $x = 0.45$  m from the centre of the sphere.

electric field strength = .....  $\text{V m}^{-1}$  [2]

- (c) Use information from (b) to show, on the axes of Fig. 5.2, the variation of the electric field strength  $E$  with distance  $x$  from the centre of the sphere for values of  $x$  from  $x = 0$  to  $x = 0.45$  m.

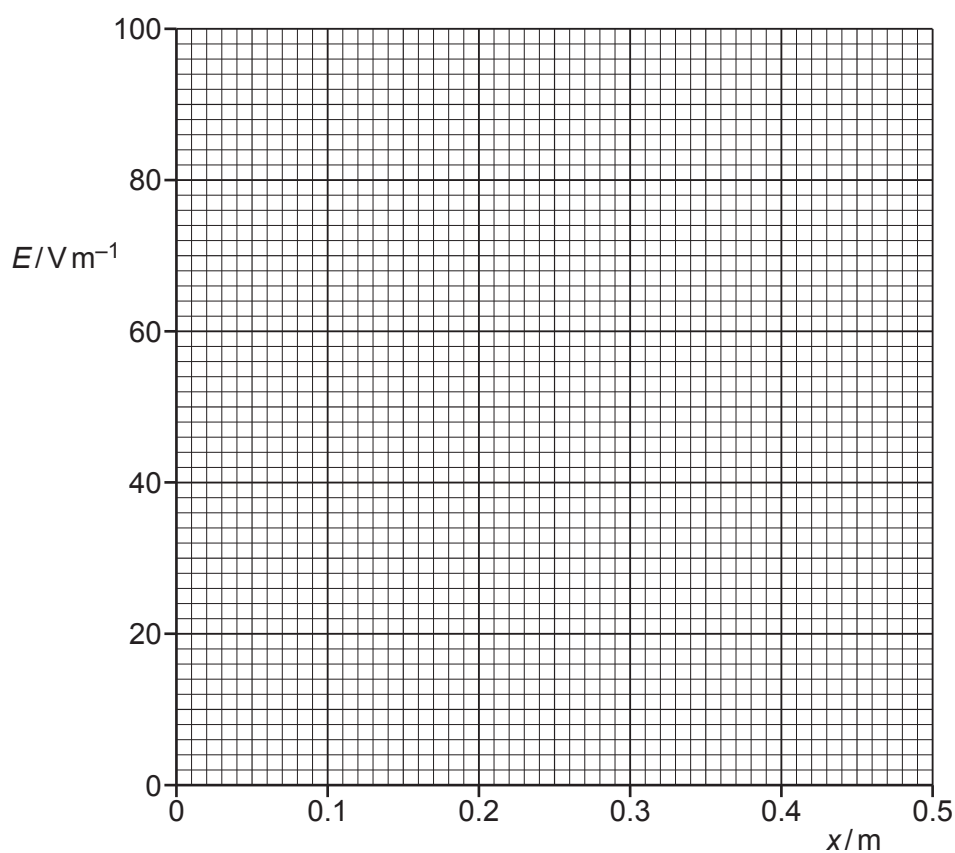

Fig. 5.2

[3]

[Total: 11]

6 (a) (i) Define the *capacitance* of a parallel plate capacitor.

.....  
.....  
..... [2]

(ii) State **three** functions of capacitors in electrical circuits.

- 1. ....
- 2. ....
- 3. .... [3]

(b) A student has available **three** capacitors, each of capacitance  $12\mu\text{F}$ .

Draw diagrams, one in each case, to show how the student connects the capacitors to give a combined capacitance between the terminals of:

(i)  $18\mu\text{F}$



[1]

(ii)  $8\mu\text{F}$ .



[1]

[Total: 7]

- 7 Electrons in a beam are travelling at high speed in a vacuum. The electrons are incident on a metal target, causing X-ray radiation to be emitted.

The variation with wavelength  $\lambda$  of the intensity  $I$  of the emitted X-ray radiation is shown in Fig. 7.1.

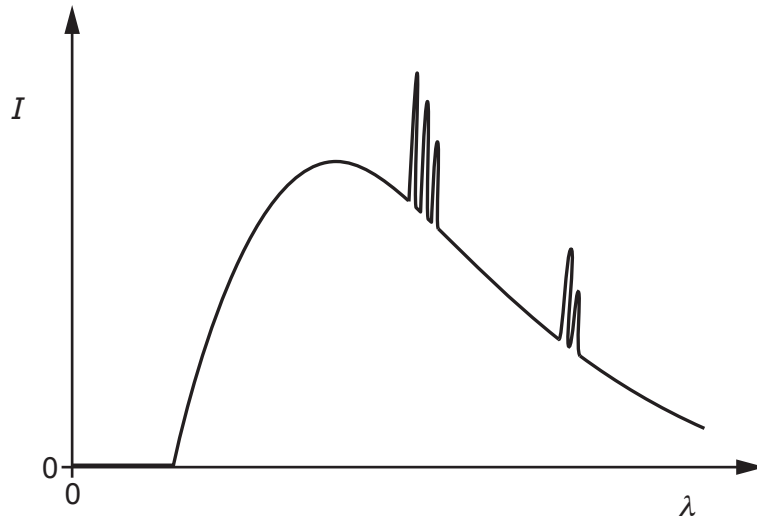

Fig. 7.1

Explain why:

- (a) there is a continuous distribution of wavelengths

.....  
.....  
.....  
.....  
..... [3]

- (b) at certain wavelengths, there are narrow peaks of increased intensity.

.....  
.....  
.....  
..... [3]

[Total: 6]

- 8 (a) An ideal operational amplifier (op-amp) is said to have infinite bandwidth and infinite slew rate.

State what is meant by:

- (i) *infinite bandwidth*

.....  
 ..... [1]

- (ii) *infinite slew rate.*

.....  
 ..... [1]

- (b) An amplifier circuit incorporating an op-amp is shown in Fig. 8.1.

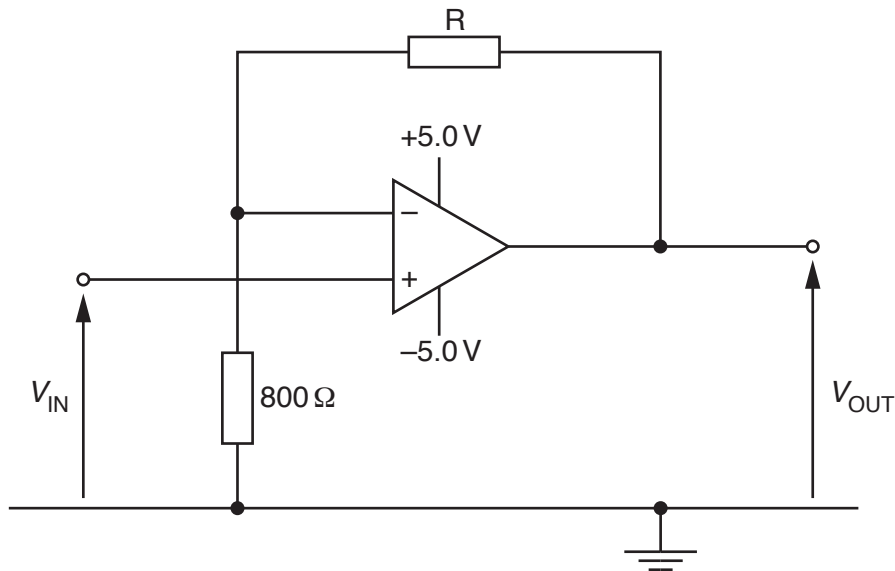

Fig. 8.1

The resistance of resistor R is to be fixed so that, for an input potential difference  $V_{IN}$  of 0.40V, the amplifier is on the point of saturation.

Determine:

- (i) the gain of the amplifier circuit

gain = ..... [2]



(ii) the resistance of resistor R.

resistance = .....  $\Omega$  [2]

[Total: 6]

- 9 (a) A small coil is placed close to one end of a solenoid connected to a power supply. The plane of the small coil is normal to the axis of the solenoid, as illustrated in Fig. 9.1.

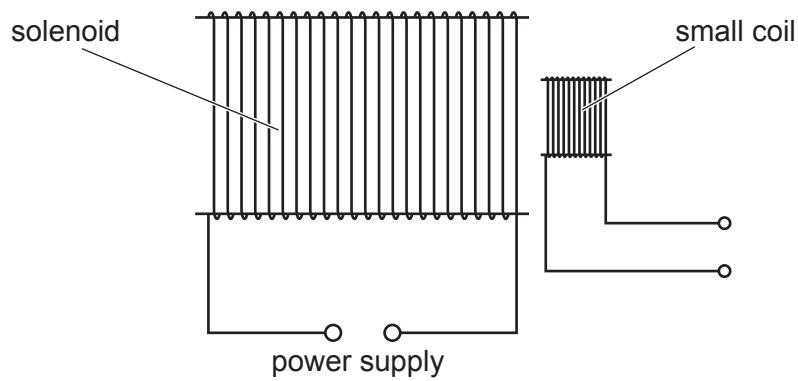
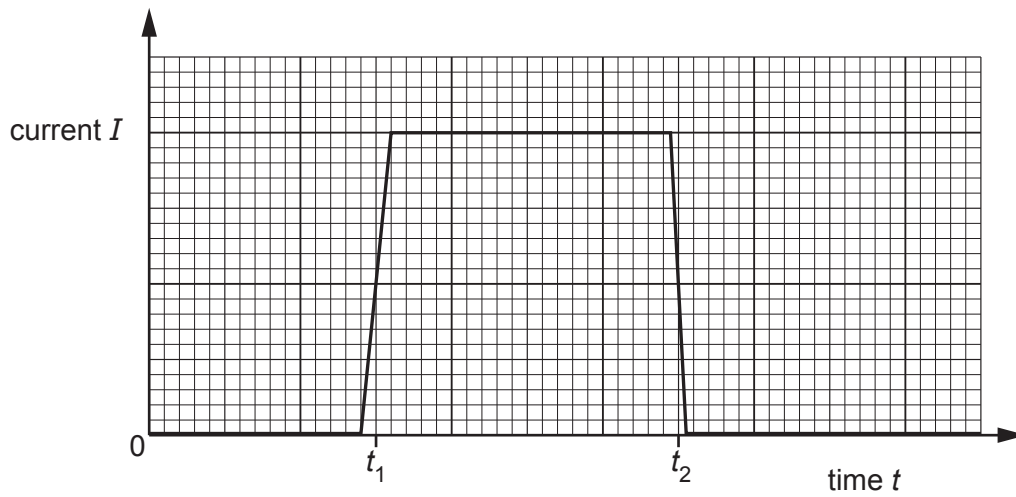

Fig. 9.1

The power supply causes the current  $I$  in the solenoid to vary with time  $t$  as shown in Fig. 9.2.

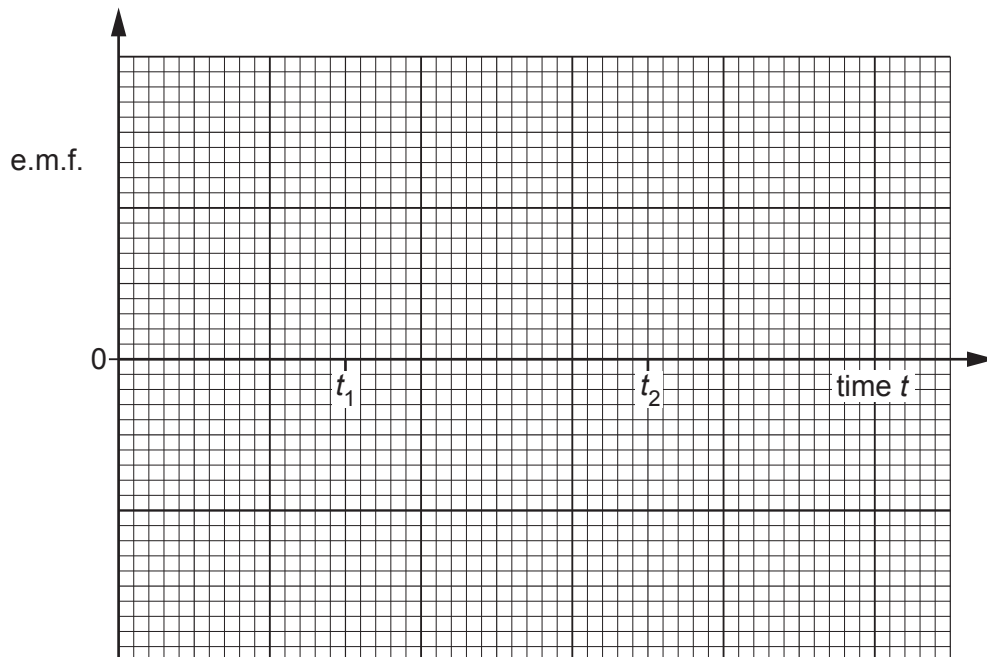

**Fig. 9.2**

- (i) State Faraday's law of electromagnetic induction.

.....  
 .....  
 ..... [2]

- (ii) On the axes of Fig. 9.3, sketch a graph to show the variation with time  $t$  of the electromotive force (e.m.f.) induced in the small coil.



**Fig. 9.3**

[4]

(b) The small coil in (a) is now replaced by a Hall probe.

The Hall probe is positioned so that the reading for the probe is a maximum.

The current  $I$  in the solenoid varies again as shown in Fig. 9.2.

On the axes of Fig. 9.4, sketch a graph to show the variation with time  $t$  of the reading  $V_H$  of the probe.

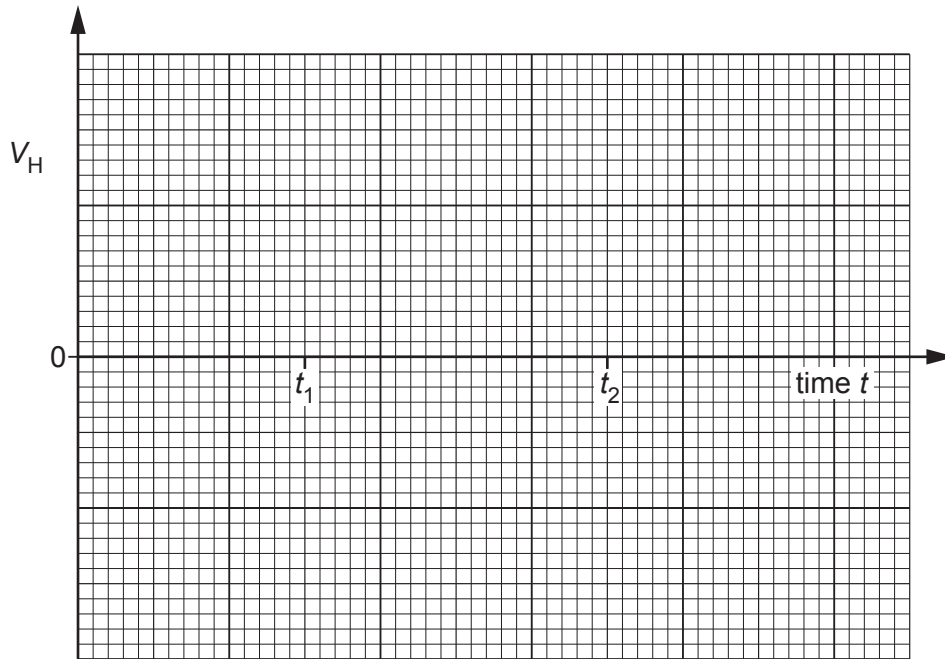

Fig. 9.4

[2]

[Total: 8]

- 10 (a) A long straight vertical wire A carries a current in an upward direction. The wire passes through the centre of a horizontal card, as illustrated in Fig. 10.1.

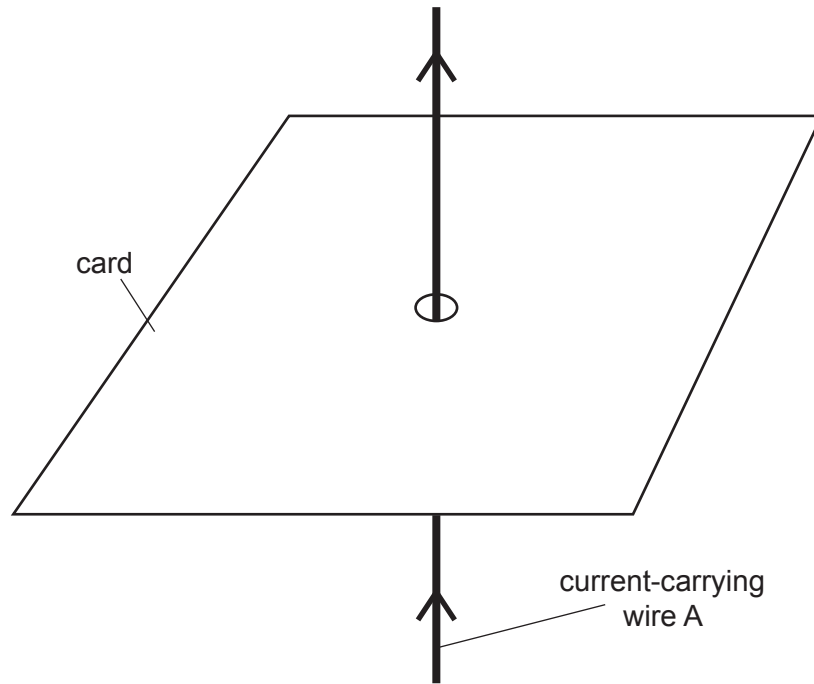

Fig. 10.1

The card is viewed from above. The card is shown from above in Fig. 10.2.

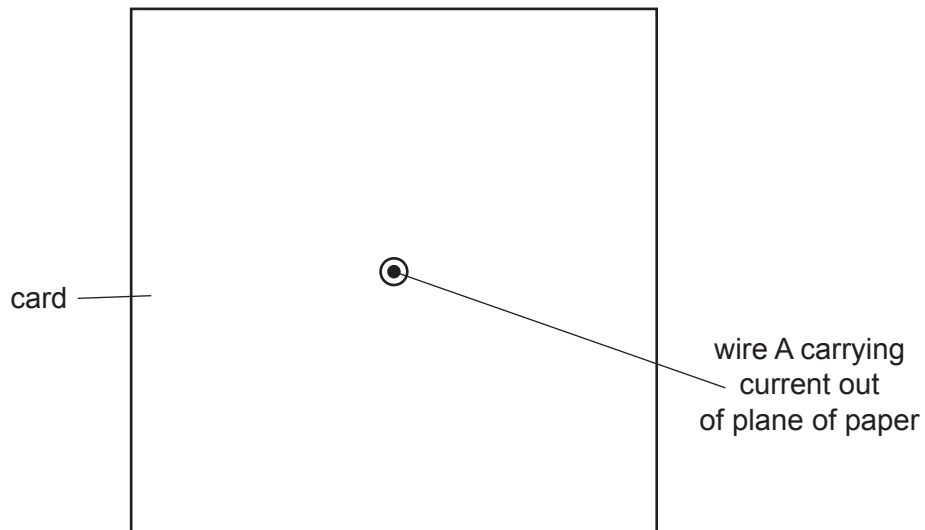

Fig. 10.2

On Fig. 10.2, draw four lines to represent the magnetic field produced by the current-carrying wire. [3]

- (b) Two wires A and B are now placed through a card. The two wires are parallel and carrying currents in the same direction, as illustrated in Fig. 10.3.

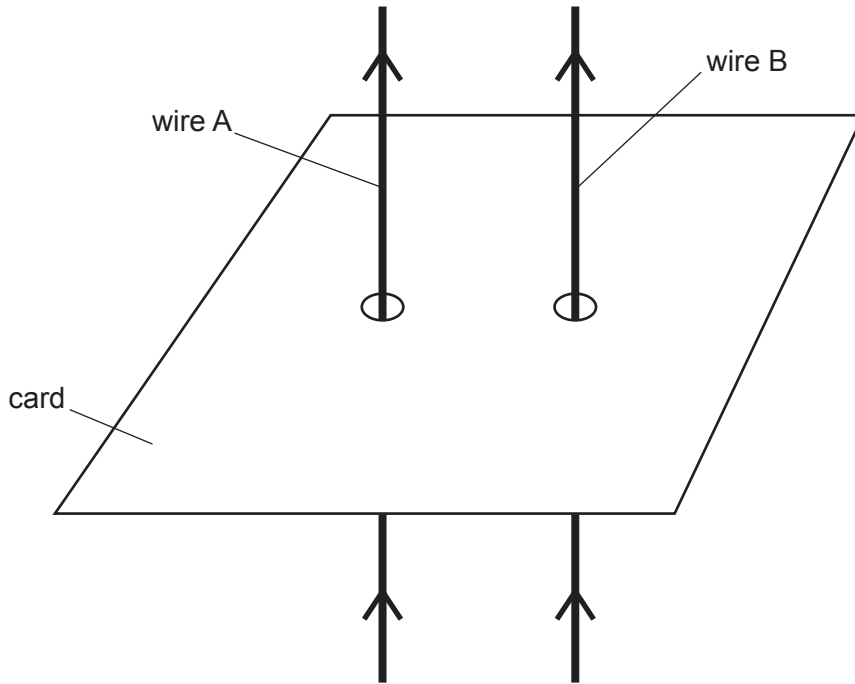

Fig. 10.3

- (i) Explain why a magnetic force is exerted on each wire.

.....  
 .....  
 .....  
 ..... [2]

- (ii) State the directions of the forces.

.....  
 ..... [1]

- (c) The currents in the two wires are not equal.

Explain whether the magnetic forces on the two wires are equal in magnitude.

.....  
 .....  
 ..... [1]

[Total: 7]

- 11 (a) Electromagnetic radiation is incident on a metal surface.

It is observed that there is a minimum frequency of electromagnetic radiation below which emission of electrons does not occur.

This observation provides evidence for a particulate nature of electromagnetic radiation.

State **two** other observations associated with photoelectric emission that provide evidence for a particulate nature of electromagnetic radiation.

1. ....

.....

2. ....

.....

[2]

- (b) The maximum kinetic energy  $E_{\text{MAX}}$  of electrons emitted from a metal surface is determined for different wavelengths  $\lambda$  of the electromagnetic radiation incident on the surface.

The variation with  $\frac{1}{\lambda}$  of  $E_{\text{MAX}}$  is shown in Fig. 11.1.

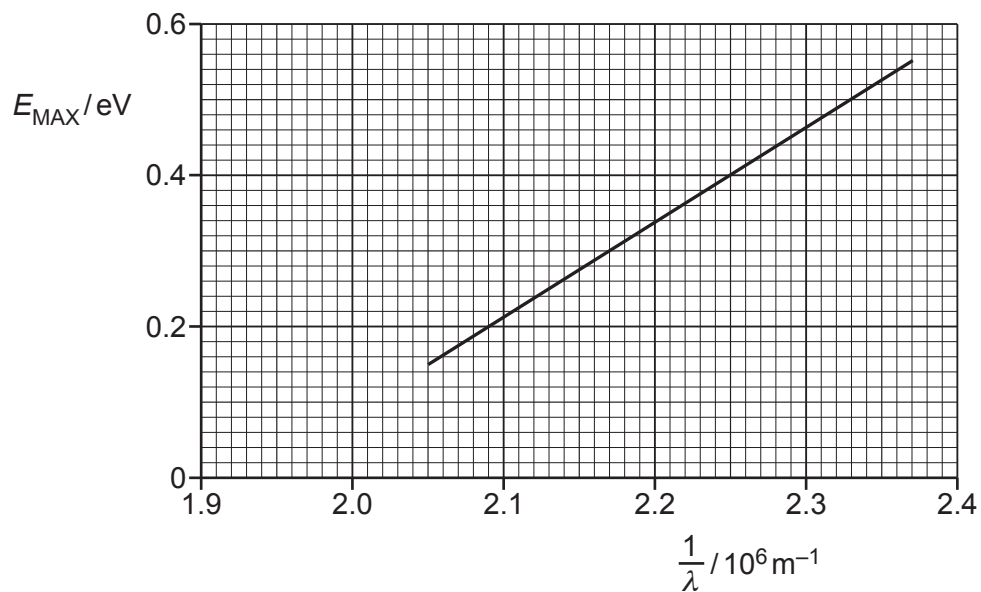

Fig. 11.1

- (i) Use Fig. 11.1 to determine the threshold frequency  $f_0$ .

$$f_0 = \dots\dots\dots \text{ Hz [2]}$$

- (ii) Use the gradient of the line on Fig. 11.1 to determine a value for the Planck constant  $h$ .  
Explain your working.

$$h = \dots\dots\dots \text{ Js [4]}$$

- (c) The electromagnetic radiation is now incident on a metal with a larger work function energy than the metal in (b).

On Fig. 11.1, sketch the variation with  $\frac{1}{\lambda}$  of  $E_{\text{MAX}}$ . [2]

[Total: 10]

12 (a) (i) Define nuclear *binding energy*.

.....  
 .....  
 ..... [2]

(ii) Explain what is meant by a *nuclear fission* reaction.

.....  
 .....  
 ..... [2]

(b) A student suggests that one possible nuclear reaction is

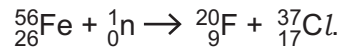

The binding energy per nucleon of a nucleus varies with the nucleon number.  
 Use this variation to explain why the reaction would **not** result in an overall release of energy.

.....  
 .....  
 .....  
 .....  
 ..... [3]

[Total: 7]

---

Permission to reproduce items where third-party owned material protected by copyright is included has been sought and cleared where possible. Every reasonable effort has been made by the publisher (UCLES) to trace copyright holders, but if any items requiring clearance have unwittingly been included, the publisher will be pleased to make amends at the earliest possible opportunity.

To avoid the issue of disclosure of answer-related information to candidates, all copyright acknowledgements are reproduced online in the Cambridge Assessment International Education Copyright Acknowledgements Booklet. This is produced for each series of examinations and is freely available to download at [www.cambridgeinternational.org](http://www.cambridgeinternational.org) after the live examination series.

Cambridge Assessment International Education is part of the Cambridge Assessment Group. Cambridge Assessment is the brand name of the University of Cambridge Local Examinations Syndicate (UCLES), which itself is a department of the University of Cambridge.